

SIMULTANEOUS SIGNAL SEPARATION IN THE TRICOLOR VIDICON*

BY

HAROLD BORKAN

RCA Laboratories,
Princeton, N.J.

Summary—The operation of the tricolor Vidicon, a single camera tube for color television, presents a novel circuit problem. The target structure contains considerable capacitance which couples the three output electrodes. Extraction of separate color signals in the presence of this cross-coupling impedance must be performed while maintaining a satisfactory signal-to-noise ratio. This paper presents a general analysis of the problem and suggests several practical solutions. The system described involves low input impedance, feedback preamplifiers, and mixed-highs circuitry.

INTRODUCTION

A NOVEL circuit problem is encountered in the design of camera equipment associated with the tricolor Vidicon,¹ a developmental camera tube for color television. The tricolor tube has three output electrodes for delivering three electrical signals corresponding to the red, green and blue information contained in the scene. However, the three output signals are coupled together by the large inherent capacitance of the target structure. The problem is to extract separate color signals in the presence of the cross-coupling impedance while maintaining a satisfactory signal-to-noise ratio.

The target of the tricolor Vidicon, shown in Figure 1, contains color filters in a repetitive sequence of red, green and blue strips. Superposed in registry with each filter is a narrower transparent conducting signal strip. All signal strips behind filters of the same primary color are connected to a common output terminal. Experimental tricolor Vidicons have been made with tube diameters of two inches and one inch. In the two-inch size, the capacitance between one set of signal strips and the other two (the inter-set capacitance) is of the order of 1200 micromicrofarads; in the one-inch size, it is of the order of 600 micromicrofarads. A single electron beam scanning the photoconductor on the target induces video signal currents in each set of strips in proportion to the primary color component.

* Manuscript received December 20, 1959.

¹ P. K. Weimer, S. Gray, C. W. Beadle, H. Borkan, S. A. Ochs, and H. C. Thompson, "A Developmental Tricolor Vidicon Having a Multiple-Electrode Target," to be published in *Trans. I.R.E.*, July, 1960.

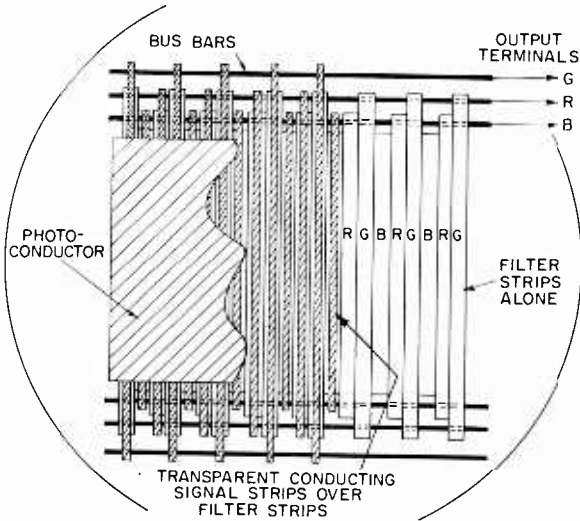

Fig. 1—Cut-away diagram of the tricolor Vidicon target as viewed from the electron gun.

INTRODUCTORY CALCULATIONS

A separate preamplifier is connected to each of the three output leads of the target. The video signal current produces voltage fluctuations in the input load resistor of each preamplifier. Ideally, each separate color signal should be amplified only by its corresponding preamplifier. Actually, because of the inter-set capacitance, it is possible for the signals of higher frequency to cross-couple. An equivalent circuit of the target is shown in Figure 2 as a delta whose sides

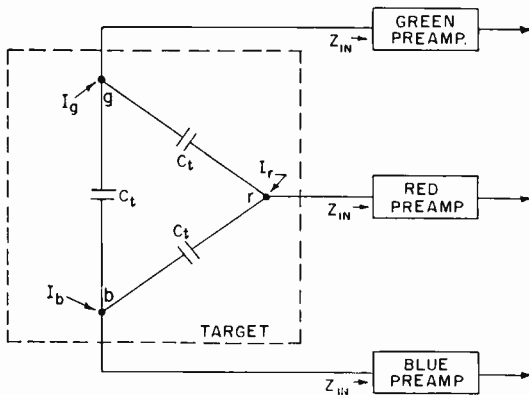

Fig. 2—Equivalent circuit of the tricolor Vidicon target.

are the cross-coupling capacitances, C_i , and whose vertices are the signal strips connected to three preamplifiers with input impedances represented by Z_{in} . Complete symmetry is assumed throughout. Since the beam acts as a high-impedance source, a primary color signal is represented as a single current source driving the corresponding set of strips. In general, the signals from the three sets of signal strips are present concurrently.

Some simple calculations will serve to indicate the signal-separation problem. In Figure 2, C_i , which is one leg of the delta, has a capacitance of 600 micromicrofarads in the larger targets, and a reactance of 204 ohms at 1.3 megacycles, the upper limit of desired signal separation defined by the color-television system. Suppose conventional black-and-white preamplifiers with Z_{in} consisting of a resistor of 50,000 ohms, shunted by 30 micromicrofarads, are used. Also, imagine a scene of a green picket fence on a dark background with optical image size such that the pickets correspond to one-megacycle information. For this case, there is but one signal current, I_g , which divides and flows through the three preamplifiers according to the impedances presented: 34.4 per cent into the green and 32.8 per cent into each of the red and blue. The green picket fence would appear white on a color monitor because it would be made up of almost equal parts of green, red, and blue video signals.

The three alternative paths for I_g have impedances Z_{in} through the green preamplifier, $Z_{in} - jX_c$ through the red, and $Z_{in} - jX_c$ through the blue. If Z_{in} were much smaller than X_c , there would be one low-impedance path through the green preamplifier and two relatively high-impedance paths through the other two preamplifiers; most of the signal current would flow through the desired channel. Suppose preamplifiers of low input impedance are provided by placing a 75-ohm resistor to ground at the head of each preamplifier. The signal separation would be excellent at the lower frequencies, but would deteriorate at the higher frequencies. This method of reducing preamplifier input impedance reduces cross-talk, but, as shown below, the signal-to-noise ratio is quite poor.

The equivalent r-m-s noise current, in amperes, flowing into a camera preamplifier due to the input circuit and first amplifier stage may be expressed as²

$$I_n = \sqrt{4kTf_0} \sqrt{\frac{1}{R} + \frac{R_{eq}}{R^2} + \frac{R_{eq}}{3X_c^2}} \quad (1)$$

² H. B. DeVore and H. Iams, "Some Factors Affecting the Choice of Lenses for Television Cameras," *Proc. I.R.E.*, Vol. 28, p. 369, August, 1940.

where $k =$ Boltzmann's constant (1.38×10^{-23} Joules/ $^{\circ}$ K),
 $T =$ absolute temperature, taken as 300° K,
 $f_0 =$ upper limit of frequency band,
 $X_c =$ capacitive reactance to ground at f_0 ,
 $R =$ resistance to ground,
 $R_{eq} =$ equivalent noise resistance of the preamplifier input tube.

For a 1.3-megacycle chroma bandwidth, $X_c = 1/(4\pi f_0 C_t) = 102$ ohms (assuming Z_{in} small compared to the target reactance, and direct capacitance to ground small compared with $2C_t$ which is 1200 micro-microfarads in the larger targets). The resistance to ground, R , is 75 ohms and R_{eq} is 45 ohms (for two type 417-A triodes in parallel). Since the target presents a very large capacitance, a reduction in noise is obtained through the paralleling of input tubes.

Substituting in the above expression,

$$I_n = 1.47 \times 10^{-7} \sqrt{0.0133 + 0.0080 + 0.0014},$$

or $I_n = 0.0221$ microampere.

Since a typical total signal is 0.6 microampere peak-to-peak, or 0.2 microampere in each channel, the signal-to-noise ratio for each color is approximately 9. This poor performance is due largely to the first two terms under the radical which reflect the small value of R . Noise of any one amplifier has been assumed not to cross-talk to the other two amplifiers.

MATHEMATICAL ANALYSIS

The problem of signal separation may be analyzed from the equivalent circuit shown in Figure 3. The analysis is simplified by making the assumption of complete symmetry. The cross-coupling capacitances, C_t , between the sets of signal strips are equal and have impedances Z_t . Likewise, the impedances, Z , at the input of the three identical preamplifiers are equal, each comprising a resistor R and capacitance C in parallel. The fictitious noise-voltage generators, e_{ng} , e_{nr} and e_{nb} , represent the noise developed in each head amplifier stage, but exclude the thermal agitation noise due to R . Certainly for best design, R should be chosen very large so that its noise will be dominated by amplifier

noise. The unity-gain preamplifiers have voltage outputs, V , which include signals plus noise.

Each amplifier noise source is effectively in series with the input control grid. The Superposition Theorem is employed to sum up the effects of the three current generators in the form of voltages at r , g , and b , the vertices of the delta. For example, the total input voltage to the green preamplifier is the sum of the separate voltages produced

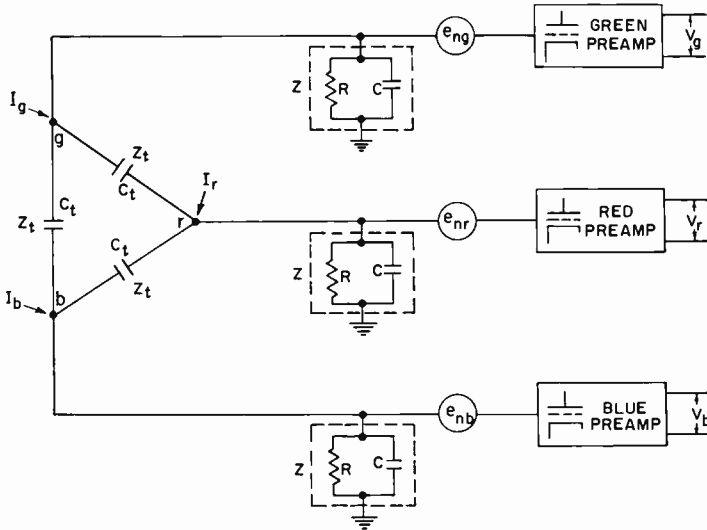

Fig. 3—Equivalent circuit for analysis.

by I_g , I_r , and I_b at g , plus the noise voltage e_{ng} . Therefore, an expression for V_g in terms of the I 's and e_{ng} is

$$V_g = I_g \frac{Z(Z + Z_t)}{3Z + Z_t} + I_r \frac{Z^2}{3Z + Z_t} + I_b \frac{Z^2}{3Z + Z_t} + e_{ng} \quad (2a)$$

The other two expressions are derived in similar fashion;

$$V_r = I_g \frac{Z^2}{3Z + Z_t} + I_r \frac{Z(Z + Z_t)}{3Z + Z_t} + I_b \frac{Z^2}{3Z + Z_t} + e_{nr} \quad (2b)$$

and

$$V_b = I_g \frac{Z^2}{3Z + Z_t} + I_r \frac{Z^2}{3Z + Z_t} + I_b \frac{Z(Z + Z_t)}{3Z + Z_t} + e_{nb} \quad (2c)$$

The solutions for the three unknown signals, I_g , I_r , and I_b , plus noise, in terms of the V 's are given below:

$$I_g + \left(\frac{2}{Z_t} + \frac{1}{Z} \right) e_{ng} - \frac{1}{Z_t} e_{nr} - \frac{1}{Z_t} e_{nb} = \left(\frac{2}{Z_t} + \frac{1}{Z} \right) V_g - \frac{1}{Z_t} V_r - \frac{1}{Z_t} V_b, \quad (3a)$$

$$I_r - \frac{1}{Z_t} e_{ng} + \left(\frac{2}{Z_t} + \frac{1}{Z} \right) e_{nr} - \frac{1}{Z_t} e_{nb} = -\frac{1}{Z_t} V_g + \left(\frac{2}{Z_t} + \frac{1}{Z} \right) V_r - \frac{1}{Z_t} V_b, \quad (3b)$$

$$I_b - \frac{1}{Z_t} e_{ng} - \frac{1}{Z_t} e_{nr} + \left(\frac{2}{Z_t} + \frac{1}{Z} \right) e_{nb} = -\frac{1}{Z_t} V_g - \frac{1}{Z_t} V_r + \left(\frac{2}{Z_t} + \frac{1}{Z} \right) V_b. \quad (3c)$$

Since all noise sources other than the first-stage shot noise have been excluded in this analysis, the above solutions are optimum. In addition, they are perfectly general, for once pure signals have been secured, regardless of the method chosen for separating signals, the indicated noise will also be present.

POSSIBLE ELECTRONIC SOLUTIONS

The mathematical solutions to the simultaneous equations indicate a direct method for solving the signal-separation problem. With the noise terms omitted, Equations (3) may be expressed as follows:

$$Z_t I_g = \left(2 + \frac{C}{C_t} \right) V_g - V_r - V_b, \quad (4a)$$

$$Z_t I_r = -V_g + \left(2 + \frac{C}{C_t} \right) V_r - V_b, \quad (4b)$$

$$Z_t I_b = -V_g - V_r + \left(2 + \frac{C}{C_t} \right) V_b. \quad (4c)$$

It has been assumed that $R \gg 1/\omega C$ and, therefore, $1/Z \approx j\omega C$.

Figure 4 is a block diagram showing how the above operations may be performed electronically. One channel is represented and only a green signal has been derived. Since the input impedance is capacitive, the subsequent stages of amplification contain correcting networks to insure that the signal is amplified uniformly irrespective of frequency.

An "electronic matrix" could be built to operate on the three observables, the V 's, and yield the three desirables, the I 's. Some disadvantages of the electronic matrix are: (1) it is critical in adjustment, since each pure color signal is obtained from the difference of two nearly identical signals; (2) the system is somewhat complex; (3) the compensation for the capacitive input impedance over the required number of frequency decades is rather awkward.

A simpler method for the solution of the signal-separation problem involves low-input-impedance preamplifiers. The previous analysis is applicable if R , the actual impedance to ground at the amplifier input,

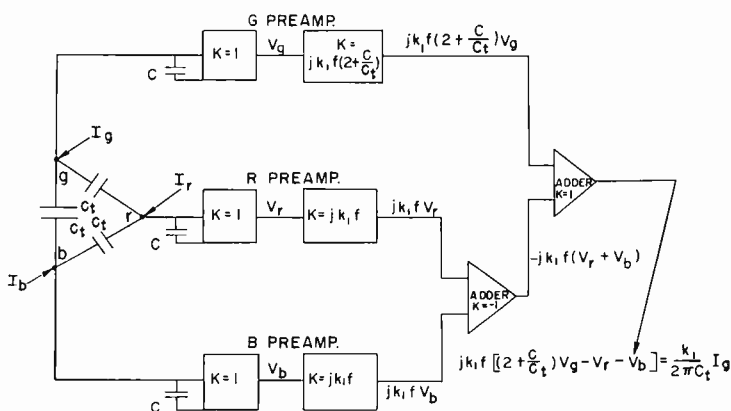

Fig. 4—One channel of the "electronic matrix."

is maintained large. If the low impedance is obtained dynamically, signal separation may be achieved while the optimum signal-to-noise ratios are approached. A dynamic impedance does not exhibit thermal-agitation noise as does a physical resistance. Two methods of dynamically obtaining a low input impedance are: (1) use of negative feedback from the output of each amplifier to its own input, and (2) use of grounded-grid amplifiers. These low-input-impedance preamplifiers do accomplish signal separation within the target. The cross-feeding of signals is accomplished by the delta of Z_t 's itself. This method, though not identical with the mathematical solutions given previously, approaches these solutions as the input impedance is made to approach zero.

Expressions for the input impedance, Z_{in} , and the output voltage, V_{out} , of a single-stage feedback amplifier shown in Figure 5, are readily derived:

$$Z_{in} = \left(\frac{Z_f}{Z_{bp}} + 1 \right) \frac{1}{g_m}, \tag{5a}$$

and

$$V_{out} = -I_{in}Z_f, \tag{5b}$$

where
$$Z_{bp} = \frac{r_p Z_b}{r_p + Z_b},$$

Z_b is the plate load impedance,

r_p and g_m are the plate resistance and transconductance of the amplifier tube, respectively,

Z_f is the impedance in the feedback path, and

I_{in} is the signal current.

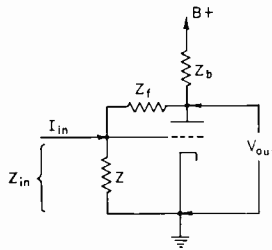

Fig. 5—Schematic diagram of the feedback preamplifier stage.

The above expressions are valid if $g_m \gg \frac{1}{Z_{bp}} + \frac{1}{Z} \left(\frac{Z_f}{Z_{bp}} + 1 \right),$

where Z is the physical impedance to ground at the preamplifier input.

If two parallel-connected type 417-A triodes are used, g_m is 0.060 mho and r_p is 750 ohms. A practical value for the plate-load resistor is 3000 ohms. If it is desired to have $Z_{in} = 75$ ohms, then Z_f must be 2200 ohms. For a signal current of 0.2 microampere peak-to-peak in each color channel, V_{out} is 440 microvolts. Assuming a large R (say 200,000 ohms) and all the above values, the imposed conditions are sufficiently satisfied.

Expressions for the input impedance and output voltage for a grounded-grid amplifier may be found in the literature and are given

below:

$$Z_{in} = \frac{Z_b + r_p}{\mu + 1}, \quad \text{and} \quad V_{out} = I_{in}Z_b, \quad (6)$$

where the amplification factor, $\mu = g_m r_p$, and all other terms are the same as previously defined. The above expressions are valid if the resistor in the cathode circuit is much greater than Z_{in} . Assuming the same plate-load resistor, the input impedance for the grounded-grid arrangement is about 81 ohms.

Neither the feedback nor the grounded-grid method requires unusual circuits subsequent to the preamplifiers and neither should be critical in operation. The feedback amplifier is more flexible because a wide range of input impedances may be obtained by inserting the proper feedback impedance. In the cathode-driven arrangement, the input characteristic is primarily determined by the input tube, which has been selected for noise considerations. It appears that a practical method of achieving signal separation is to use special low-input-impedance preamplifiers of the feedback variety.

FEEDBACK PREAMPLIFIER DESIGN

The first stage in each of the feedback preamplifiers was chosen on the basis of signal-separation and noise considerations to consist of two parallel-connected type 417-A triodes with a feedback path of 2200 ohms between the plates and grids. A cascode-connected 417-A is used as the second stage because of signal-to-noise considerations. With this arrangement, the second-stage noise has not been made negligible, but has been reduced to a reasonable value. The considerable gain obtainable from the cascode amplifier insures that the signal level at the input to the third stage will be high enough that further degradation is insignificant. The subsequent stages in the preamplifier are conventional.

THE MIXED-HIGHS SYSTEM

The present standards for color television require only 1.3 megacycles of chroma information. Since all signals, separated as well as cross coupled, pass through the preamplifiers, a total signal above this frequency may be obtained by adding the three preamplifier outputs through a high-pass filter. It is apparent that a signal obtained by summing Equations 3a, 3b, and 3c results in a cancellation of the larger noise terms, since noise originating in one channel appears reversed in phase in the other channels. This feature may be referred to as "correlated noise."

A method of utilizing the correlated noise to improve the signal-to-noise ratio of the tricolor Vidicon is shown in block diagram form in Figure 6. The signals are fed directly into three feedback preamplifiers, each presenting a low input impedance, where they are amplified to about 0.5 volt peak-to-peak. The signals then pass into a level setter which establishes a reference voltage related to black-level during horizontal retrace time. The signals then split up into two paths. One path is through the mixed-highs adder which combines the three signals and passes them through a high-pass filter. This is the mixed-highs channel which carries information made up of equal parts of the original red, green, and blue signals above 1.3 megacycles. The other path for each signal is through a low-pass 1.3-megacycle filter.

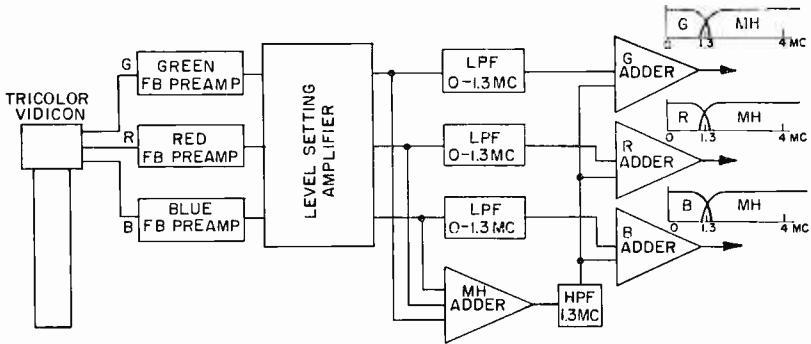

Fig. 6—Mixed-highs system for providing noise reduction in tricolor Vidicon signals.

Since the preamplifiers have separated the color information out to beyond this frequency, each of these three signals contain information of essentially one primary color. The mixed highs are added to each of the color signals in the final adders. The resultant signals may be fed to a simultaneous monitor or used to produce the standard color signal.

EVALUATION OF THE FEEDBACK METHOD

The feedback preamplifier method of signal separation is evaluated by an analysis of two factors—signal separation ability and signal-to-noise ratio. Figure 7 is a phasor diagram illustrating the magnitude and phase of the three output signals produced by a pure primary color as a function of signal frequency. All sources of cross-talk other than capacitive coupling through the target have been neglected. The diagram is applicable to both two-inch and one-inch targets having the

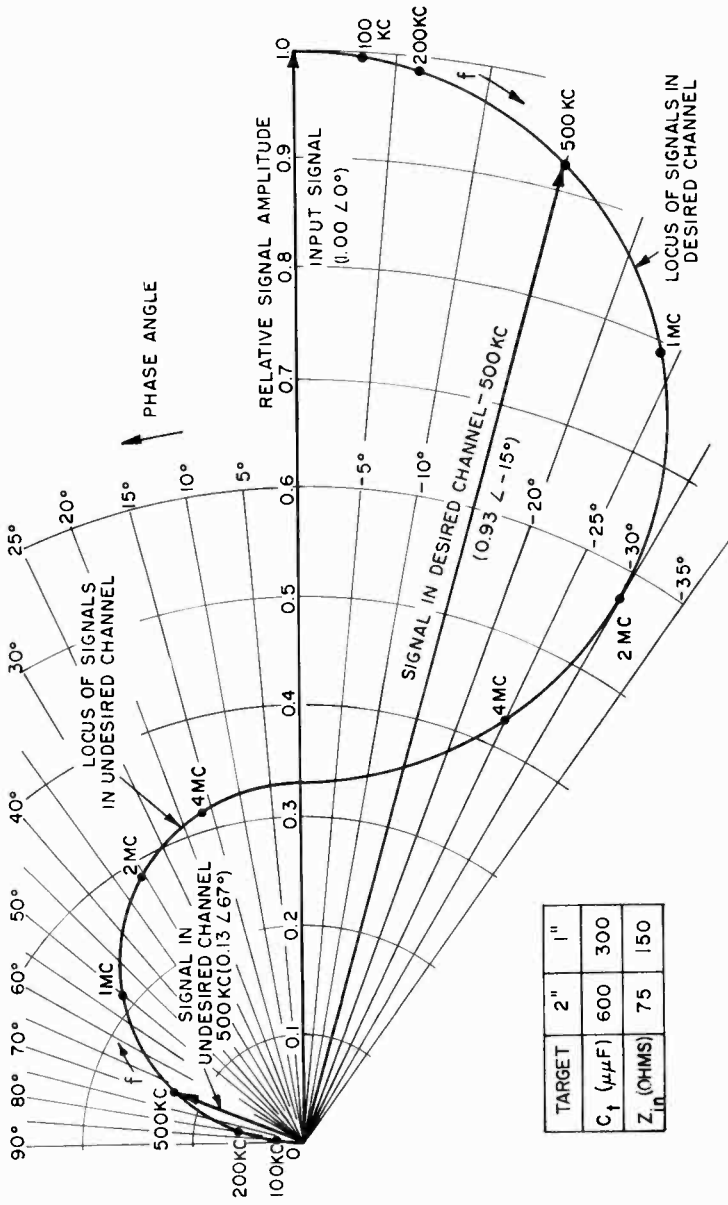

Fig. 7.—Phasor diagram showing signals in desired and undesired channels for primary color signals of various frequencies (500-kilocycle signal illustrated).

values of C_t and Z_{in} indicated. While the graph shows color mixing at the higher frequencies, subjectively it has been found that the residual color cross talk is acceptable, since the eye is not sensitive to chromatic differences in small areas. However, should a lower value of input impedance be desirable, it is attainable with slight additional noise degradation in the mixed highs due to the second amplifier stage.

In the appendix, optimum values for signal-to-noise ratios have been calculated to be 29 for each color channel and 330 for the mixed highs. These values are for a 0.6-microampere peak-to-peak white signal. The calculated value for each color channel is determined only by first-stage amplifier noise.

Since thermal agitation noise, beam noise, and second-stage noise are found to be negligible when compared with first-stage amplifier noise, the feedback preamplifier signal-to-noise ratio for color information is reasonably close to the optimum value. In practice the system appears better than the calculated value, because of noise cancellation at the picture tube. To a limited extent, noise addition is performed by the observer viewing the picture tube, and some noise cancellation is effected. Thermal agitation and beam noise may also be neglected for the mixed-highs channel, but second-stage noise is appreciable. Its effect is to further reduce the attainable signal-to-noise ratio from the optimum value.

The optimum signal-to-noise ratios assume realistic amplifying tubes and load resistors. If lower-noise amplifier tubes become available, performance will naturally improve. However, one can parallel more tubes at the input and improve the signal-to-noise ratio in color while not appreciably damaging the signal-to-noise ratio in the mixed highs. The prime obstacle to both perfect signal separation and high signal-to-noise is the inherent inter-set capacitance. The color channel signal-to-noise ratio varies inversely as this capacitance and the chromatic cross-talk varies approximately as the capacitance.

THE TRICOLOR VIDICON IN THE COLOR TELEVISION SYSTEM

The simultaneous signals from the tricolor Vidicon processed by the mixed-highs circuits may be used to form the standard signal in the usual manner. The standard signal could likewise be produced without the mixed-highs circuits but would benefit less from the correlated nature of the noise. While the specific signal-to-noise ratios have been computed for the output signals of the system shown in Figure 6, the same technique may be used in calculating signal-to-noise ratios for the E_Y , E_I , and E_Q signals.

The analysis has shown that minimum noise occurs when the

simultaneous signals are combined equally. A tricolor Vidicon made with relative sensitivities in each color channel corresponding to the luminance coefficients, would offer reduced noise compared with a tube made with equal sensitivities. The additional noise arising from the inter-set capacitance could then be confined to the chrominance channels and excluded from the luminance. This feature would contribute to reduced noise visibility on both color and black-and-white receivers.

ACKNOWLEDGMENT

The author is indebted to P. K. Weimer under whose direction this work was performed. The contribution to the analysis of the noise problem by D. O. North is greatly appreciated. In addition, thanks are due to H. L. Oehme for constructing the equipment.

APPENDIX

The optimum values for signal-to-noise ratios in each color channel and in mixed highs may be calculated from Equations (3). While the assumed noise sources in the expressions are voltage generators, in combination with the modifying impedance terms they represent noise currents.

The equivalent noise current in each color channel, calculated from Equation (1) with R assumed large, is represented as

$$\sqrt{4kTf_0} \sqrt{\frac{R_{\text{eq}}\omega_0^2 C_0^2}{3}}, \quad (7)$$

where $f_0 = \omega_0/2\pi$ is the upper frequency limit of desired color information (taken as 1.3 megacycles); k , T , and R_{eq} are the same quantities previously defined; and C_0 is the total effective input capacitance. C_0 is determined by the coefficients of the noise terms in Equation (3a). Thus

$$C_0 = \sqrt{(2C_t + C)^2 + (C_t)^2 + (C_t)^2}, \quad (8)$$

or $C_0 \approx \sqrt{6} C_t$ for C much smaller than C_t . With $R_{\text{eq}} = 45$ ohms and $C_t = 600$ micromicrofarads, the equivalent noise current for each color channel is 0.00682 microampere. The signal-to-noise ratio is then 29 for a signal current of 0.2 microampere peak-to-peak in that channel. It has been assumed that beam noise from the camera tube is negligible.

The optimum signal-to-noise ratio for the high frequencies is evaluated by the sum of Equations (3).

$$I_g + I_r + I_b + \frac{1}{Z} (e_{ng} + e_{nr} + e_{nb}) = \frac{1}{Z} (V_g + V_r + V_b). \quad (9)$$

Equation (1) is for a pass-band 0 to f_0 . The corresponding expression for a pass-band f_1 to f_2 is easily derived and may be expressed:

$$I_n = \sqrt{4kT(f_2 - f_1)} \sqrt{\frac{1}{R} + \frac{R_{eq}}{R^2} + \frac{R_{eq}}{3X_c^2}} \quad (10)$$

where $X_{\bar{c}} = \frac{1}{2\pi\bar{f}C}$ with $\bar{f} = \sqrt{f_1^2 + f_1f_2 + f_2^2}$. From Equations (9) and (10), with R assumed large, the equivalent noise current in the mixed-highs channel is given by

$$2\pi\bar{f}C \sqrt{4kT(f_2 - f_1)R_{eq}}, \quad (11)$$

where

$$f_2 = 4.2 \text{ megacycles,}$$

$$f_1 = 1.3 \text{ megacycles,}$$

and

$$\bar{f} = 4.9 \text{ megacycles.}$$

Since C may be assumed to be 40 micromicrofarads, the equivalent noise current is 0.00182 microampere. The corresponding signal-to-noise ratio is then about 330 for a total signal of 0.6 microampere peak-to-peak.