

→ Chan Richter, we discussed his  
please return to me  
Tony.



**LB-1043**

**THE TRICOLOR VIDICON**

**A DEVELOPMENTAL CAMERA TUBE**

**FOR COLOR TELEVISION**

GC CD ES JS P.S.  
JWD JCN LES MF  
**RECEIVED**  
OCT 10 1956  
G. R. TUBE ENGINEERING  
NOTE FILE DISCUSS  
ANS RETURN LOG

**RADIO CORPORATION OF AMERICA**

**RCA LABORATORIES**

**INDUSTRY SERVICE LABORATORY**

**RADIO CORPORATION OF AMERICA**  
**RCA LABORATORIES**  
**INDUSTRY SERVICE LABORATORY**

**LB-1043**

**THE TRICOLOR VIDICON**  
**A Developmental Camera Tube for Color Television**

This report is the property of the Radio Corporation of America and is loaned for confidential use with the understanding that it will not be published in any manner, in whole or in part. The statements and data included herein are based upon information and measurements which we believe accurate and reliable. No responsibility is assumed for the application or interpretation of such statements or data or for any infringement of patent or other rights of third parties which may result from the use of circuits, systems and processes described or referred to herein or in any previous reports or bulletins or in any written or oral discussions supplementary thereto.

**Approved**

*Stuart W. Lee*



Color television cameras now widely used require three separate pickup tubes to supply the simultaneous primary color information transmitted by the compatible system. This bulletin describes a new developmental tube, called the tricolor Vidicon, which permits a single-tube camera whose compactness and technique of operation resemble that of a black-and-white camera. The ability to generate the three simultaneous signals is achieved in the tricolor Vidicon by means of an intricate target structure having three interlocking groups of color-sensitive strips connected to separate output terminals for each primary color. A single low-velocity electron beam scans the photoconductive target. No special requirements are made on the beam with respect to focus or scanning accuracy. Registry of the three signals is inherent in the design of the target.

### Introduction

The signal transmitted in the compatible color television system used in this country is formed by encoding three simultaneous independent video signals. In the widely used camera<sup>1</sup> the simultaneous information is derived from three separate pickup tubes. The light from the scene is split by means of dichroic mirrors, as shown in Fig. 1, to form separate red, green, and blue images on the sensitive surfaces of the three tubes. Optical and electrical registry of the three images is maintained in order to preserve the required resolution.

For the past several years research has been in progress at the RCA Laboratories on a new tricolor camera tube which generates directly the three simultaneous signals. The resulting single-tube camera uses conventional lenses and resembles a black-and-white camera in compactness and operation.

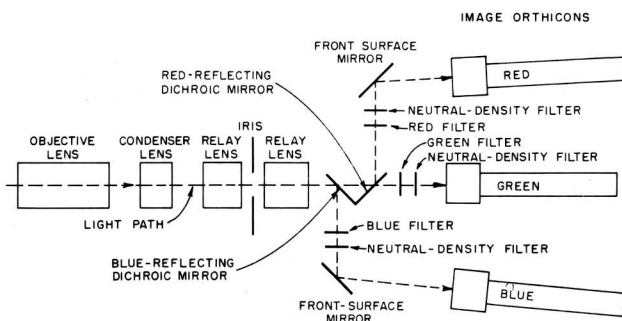

Fig. 1 - Optical lens system of a color television camera using three image orthicon pickup tubes.

1. J.D. Spradlin "The RCA Color Television Camera Chain" *RCA Review*, Vol. XIII p. 11, March, 1952.

This bulletin will describe the basic principles and operating characteristics of the new tube which is called the tricolor Vidicon. The present developmental form of the tube has a sensitivity well below conventional pickup tubes; achievement of the sensitivity desired for studio pickup must await the development of improved photoconductors. Considerable tube development work also remains to be done before the tricolor Vidicon can be made commercially available.

### General Description of the Tricolor Vidicon

The ability to generate three independent simultaneous video signals is achieved in the tricolor Vidicon by means of an intricate target structure having three interlocking groups of color sensitive strips connected to a separate output terminal for each primary color. An experimental model of the tricolor Vidicon is shown in Fig. 2 with a standard black-and-white image orthicon in the background. The light-sensitive target of the Vidicon has a picture diagonal of 1.5 inches, the same as that of the image orthicon. The new tube can be operated in a modified black-and-white image orthicon camera using standard lenses.

A cross sectional diagram of the tricolor Vidicon is shown in Fig. 3. A low velocity electron beam from a single gun scans the light-sensitive color target which is formed on the inside face of the tube. No special requirements are made on the electron beam, either in terms of focus or scanning accuracy. Registry of the three signals is inherent in the design of the target.

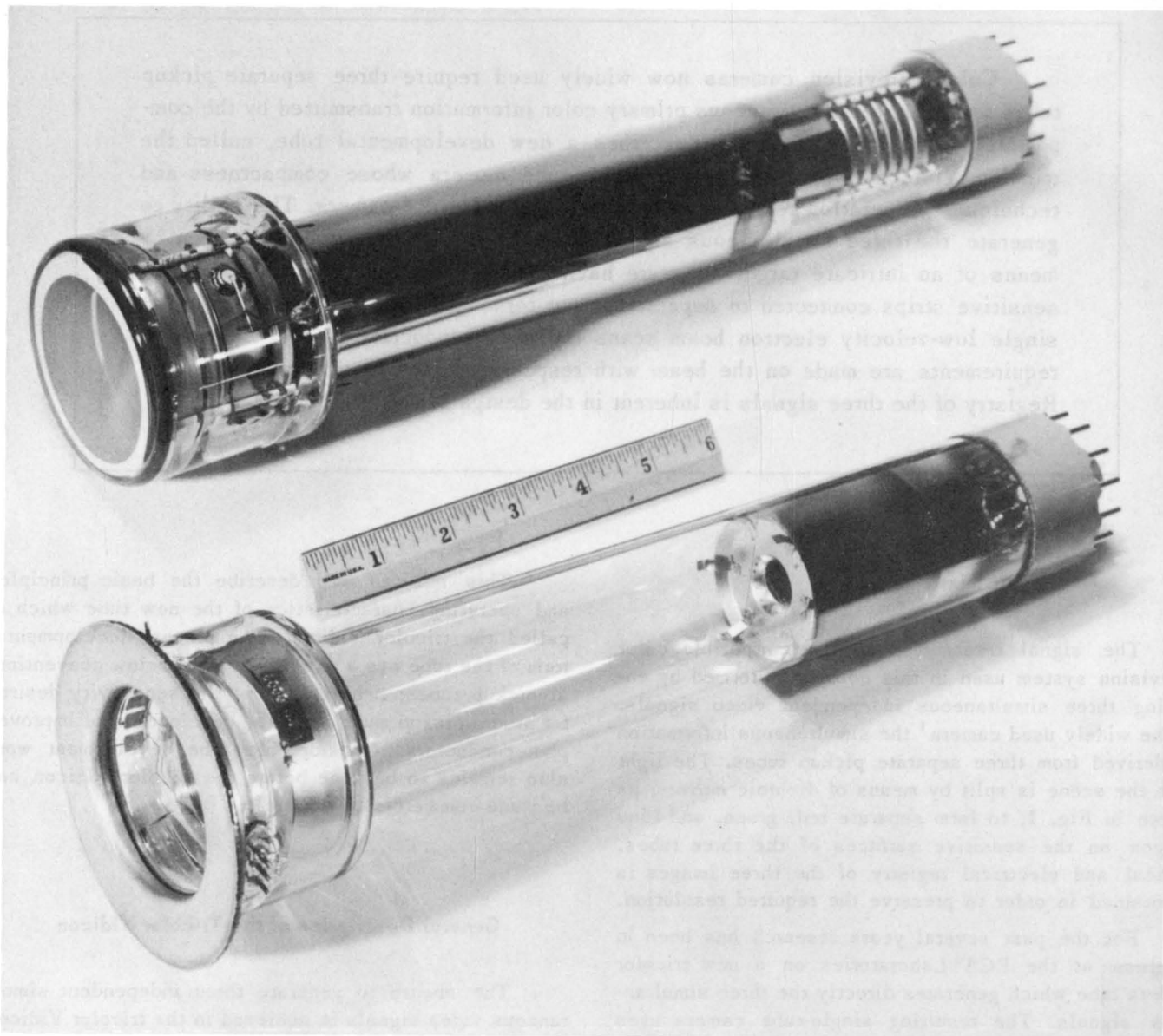

Fig. 2 - A developmental Tricolor Vidicon with a standard black-and-white Image Orthicon in the background.

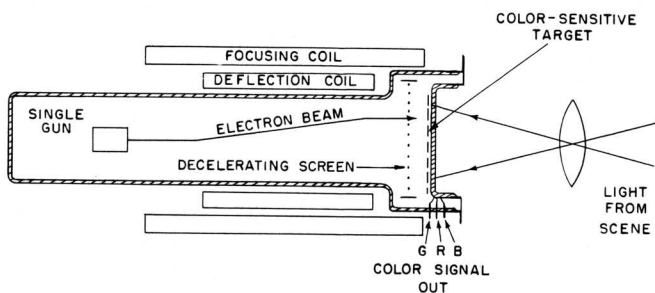

Fig. 3 - Cross-sectional diagram of the developmental Tricolor Vidicon. Three separate output terminals near the target provide simultaneous color signals.

### Description of the Color-Sensitive Target

An enlarged view of an experimental tricolor Vidicon target is shown in Fig. 4. Color filters are built into the target in a repeated sequence of very fine vertical strips of red, green, and blue transmission. Covering the filter strips are three sets of interlocking semitransparent conducting signal strips. The signal strips corresponding to a given color are insulated from their neighbors, but interconnected by means of *bus bars* to a common output terminal for that color. The target whose performance is to be described has approximately 290 strips of each color, making a total of 870 strips.

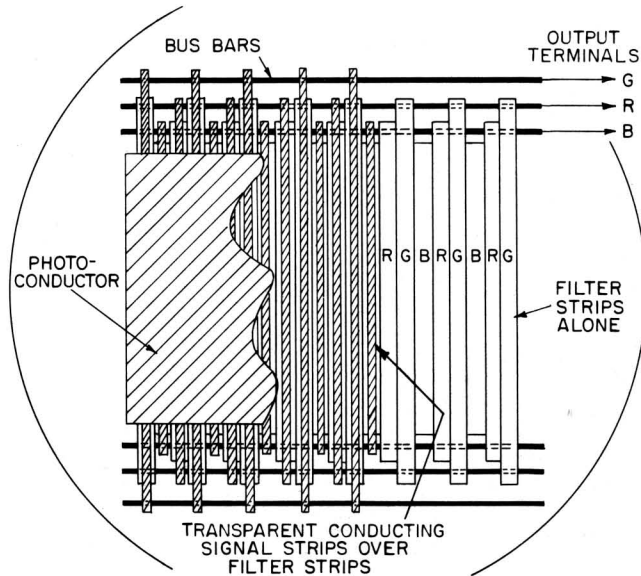

Fig. 4 - Cut-away diagram of the Tricolor Vidicon target as viewed from the electron gun of the tube.

Fig. 5 shows in greater detail the method of connecting the signal strips to the bus bars, which extend along the top and bottom of the picture area. The signal strips consist of a film of metal, so thin as to be semi-transparent, laid down in strips approximately 0.001 inch wide. The space between the strips is a few ten-thousandths of an inch wide. The bus bars are relatively thick metallic strips deposited on the glass. Cross-over insulation for the signal strips is provided by the filters themselves which extend over the inner bus bars as shown. By connecting the signal strips to bus bars at both the top and bottom of the target the possibility of open strips arising from defects is greatly reduced. Many experimental targets have been made which were entirely free of either open lines or shorts.

A uniform layer of photoconductive material is deposited over the top of the signal strips as shown in the

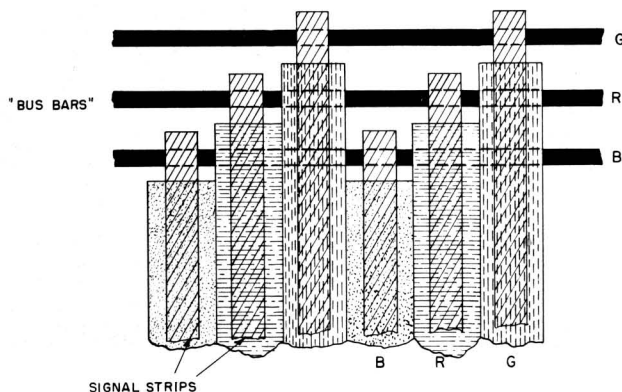

Fig. 5 - Detail of the Tricolor Vidicon target showing signal strip-bus bar connections. The insulating filter strips permit the signal strips to cross over the inner bus bars as shown.

sectional view of the target of Fig. 6. The thickness of the various layers is greatly exaggerated in this drawing.

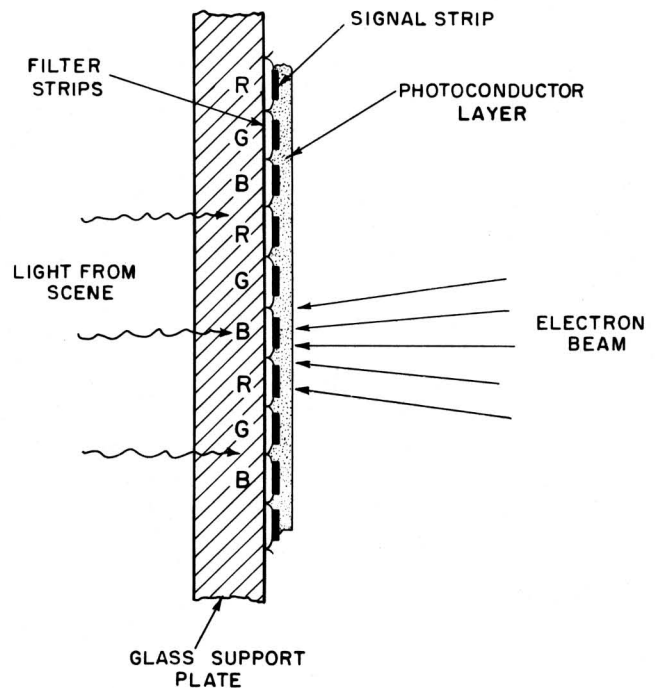

Fig. 6 - Cross section of the Tricolor Vidicon target with the signal strips viewed end-wise.

### Fabrication of the Tricolor Target

Several widely different techniques for producing the tricolor target structure are possible. The choice of method is considerably narrowed by the rigid specifications on fineness and precision and by the requirement that the target withstand tube processing.

The target described above was formed by evaporation of the filter and signal strip materials through fine grills. A precision jig was developed having the necessary controls to permit many operations to be carried out in sequence with one evacuation. This technique has many advantages for experimental targets. An evaporator and jig suitable for making color targets is shown in Fig. 7.

The filters now used are of the multilayer interference type consisting of alternate layers of high and low index materials. In the optical design of these filters, it is necessary to take into account the reflectance of the thin metal signal strip as well as the optical characteristics of the photoconductor. Fig. 8 shows a typical set of transmission curves for each of the primary filters in combination with its conducting signal strip. The ordinates show a peak transmission relative to air of about 30 to 60 percent with rejection bands which fall to less than one percent of the peak.



Fig. 7 - View of an evaporation system with the precision jig in place for making Tricolor Vidicon targets.

Other types of filters have also been used. These include absorption filters and interference filters of the Fabry-Perot type using layers of thin metal separated by a dielectric spacer. In the latter type the filter and signal strip are one integral unit.

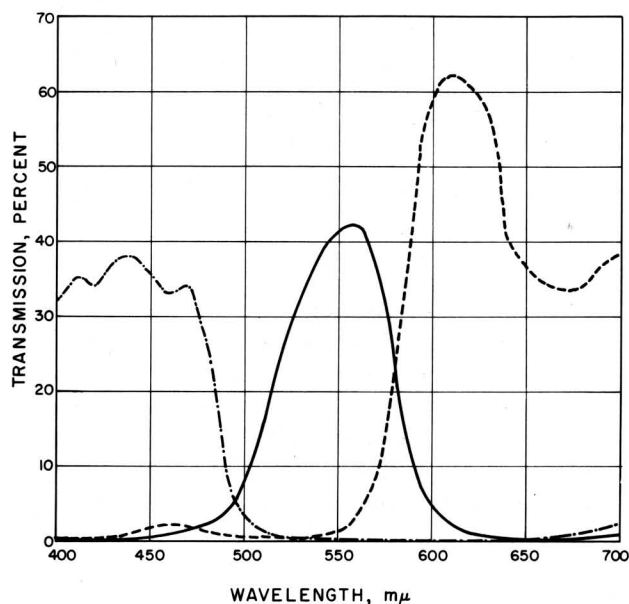

Fig. 8 - Transmission characteristics of a set of multi-layer interference filter strips overlaid with conducting signal strips as used in the Tricolor Vidicon.

### Operation of the Tricolor Vidicon

The light from the scene to be transmitted is imaged by means of a standard turret-mounted lens on to the color-sensitive target. The charge-discharge cycle of each elemental area of the photoconductor is identical to that of the black-and-white Vidicon.<sup>2</sup> The signal strips may be operated at a common potential, some thirty or forty volts positive with respect to the thermionic cathode of the gun. In the absence of light the scanned surface of the photoconductor is charged to gun cathode potential. Light from the scene passes through the filters and is absorbed in the photoconductor causing its conductivity over each strip to be increased in accordance with the intensity of that primary color component. Three independent but interlocking charge patterns build up on the surface of the photoconductor during the interval between scans, the brightest areas becoming several volts positive with respect to the gun cathode. The simultaneous discharge of the three charge patterns by the scanning beam causes separate video signal currents to be induced in each set of signal strips. By connecting each of

the three output leads to an amplifier of proper design, independent color signals are obtained for each primary color.

### Effect of Capacitance Between Signal Strips

The large capacitance existing within the target between the three sets of strips would cause severe mixing of the colors if used with conventional camera preamplifiers. An equivalent circuit of the target is represented in Fig. 9 by a delta in which the vertices are the signal strips, and the arms are the cross-coupling capacitances whose value in the target described is about 600  $\mu\mu\text{f}$ . This corresponds to a reactance of about 200 ohms at a frequency of 1.3 mc, the upper limit of desired signal separation. Thus, if one wishes to obtain separable color signals directly from the target, the amplifier input impedance should be small compared to 200 ohms. The conventional camera preamplifier has an input resistor of 50,000 ohms, a value which gives a satisfactory signal-to-noise ratio. If one attempts to achieve the required low impedance by simply reducing the input resistor of the amplifier, the thermal noise and tube noise will rise in comparison to the signal to an excessively high value. The problem is readily solved by employing large input resistors and separating the color signals by suitable circuitry. A method which has proved especially simple employs negative feedback in each amplifier, to reduce the input impedance. By this means satisfactory separation of the color signals with an acceptable signal-to-noise ratio has been obtained.

The results of a rigorous analysis of the preamplifier noise problem for the tricolor Vidicon may be summarized as follows:

- (1) The inherent noise level in each color signal

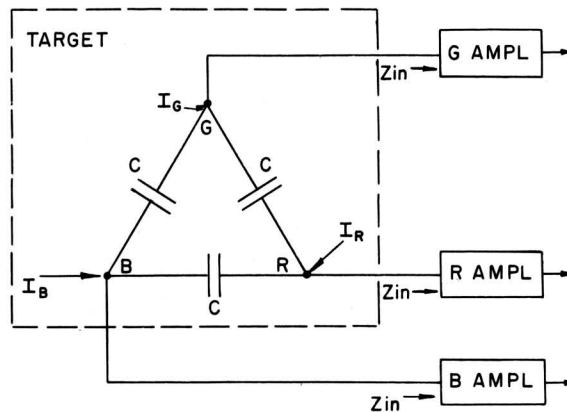

Fig. 9 - The interstrip capacity C of the Tricolor Vidicon target which permits cross coupling of color signals unless special low impedance preamplifiers are used. The value of C in the target described is approximately 600  $\mu\mu\text{f}$ .

2. Weimer, Fergue and Goodrich, "The Vidicon—A Photoconductive Camera Tube." *Electronics*, May, 1950.



may be resolved into two components: a small component whose magnitude is comparable to that obtained with usual black-and-white targets, and a second, much larger component whose magnitude is proportional to the interstrip capacitance.

The larger, and predominate, noise components arising in the three channels by virtue of the interstrip capacitance are so correlated that the noise in one channel is equal and opposite to the sum of the noise currents in the other two channels. Thus, if the output signals from all three preamplifiers were combined, the large correlated noise component in each channel would be completely cancelled out, leaving a smaller residual component whose value is only slightly larger than that obtained with a conventional Vidicon target and amplifier.

A desirable consequence of the correlated nature of the noise arising from interstrip capacitance is that its effect can be largely confined to the chrominance signals and excluded from the luminance signal. The *mixed highs* circuit shown in Fig. 10 permits an effective noise reduction by taking advantage of the fact that the system is not required to transmit separate color information in the high frequency portion of the spectrum. The interstrip noise does not contribute to the high frequency signal because it is cancelled out in the addition process. Although this noise component is not removed circuit wise for the low frequencies, its visibility is reduced at the kinescope because of correlation. In practice, a signal output of approximately 0.2 microampere in each color is sufficient to produce a color picture which is substantially free of noise.

**Performance**

Developmental models of the tricolor Vidicon have been operated in an experimental camera the same size as the black-and-white image orthicon camera. Motion picture film, color slides, and studio scenes have been used for tests. Color pictures have been transmitted which although not of broadcast quality may be considered encouraging for a developmental pickup tube. Further development leading to production under factory-controlled conditions is, of course, necessary to meet the high picture quality standards of commercial broadcasting.

*Resolution*

Color pictures transmitted by the tricolor Vidicon have been photographed in black-and-white and in color. Fig. 11 is a reproduction of a test pattern as seen on a 10 inch\* black-and-white monitor with the applied signal formed by adding the separate signals from the red, green, and blue preamplifiers. Fig. 12 is the same picture in which the signal from only the red channel is displayed. The video passband is limited to about 3.5 megacycles by means of low pass filters to simulate the picture as viewed on a black-and-white receiver.

The vertical streaks visible in some parts of the transmitted pictures shown in Figs. 11 and 12 are caused by non-uniform spacing of the evaporation grills used in making the experimental targets. If the grills were evenly spaced no streaks would be observed since the basic strip pattern is too fine to appear directly in the transmitted picture even when the signal from each channel is examined separately. The frequency generated by a well-focused beam scanning across the strips is about 5.5

\*Diagonal measurement.

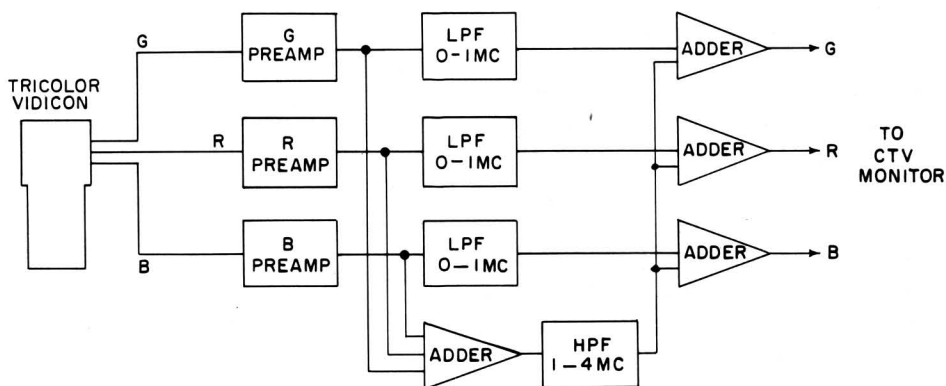

Fig. 10 - 'Mixed-high' circuit for reducing the noise arising from the interstrip capacity in the Tricolor Vidicon target. This procedure can be used profitably without deterioration of color response for television systems which do not require color discrimination for the high frequency portion of the video signal.

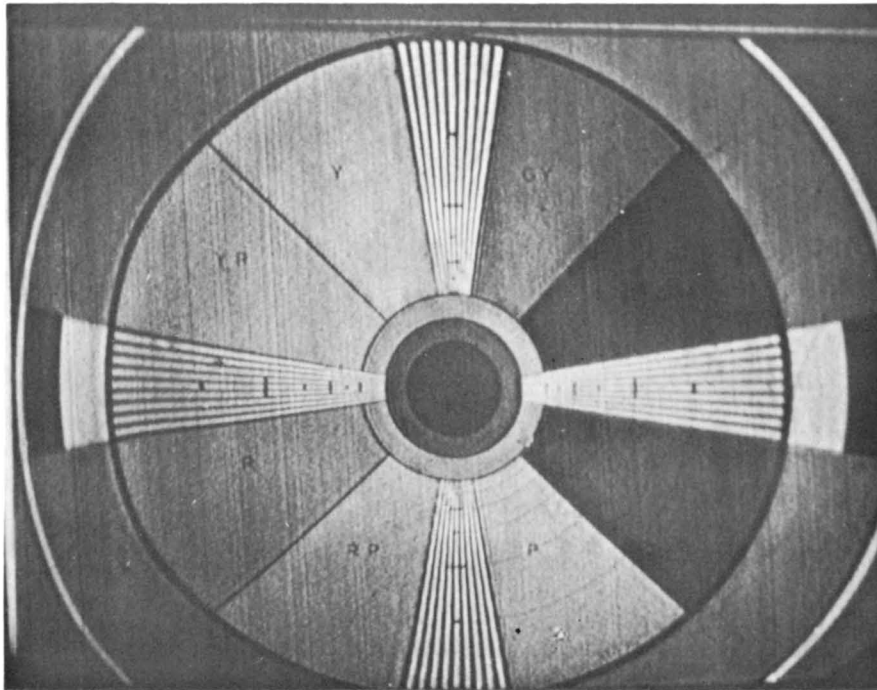

Fig. 11 - Photograph of a test pattern transmitted by a developmental Tricolor Vidicon. Three output signals were added together and displayed on a black-and-white monitor. The streaks visible in some parts of the picture are not inherent but arise from non uniform spacing of the evaporation grill used in fabricating the target.

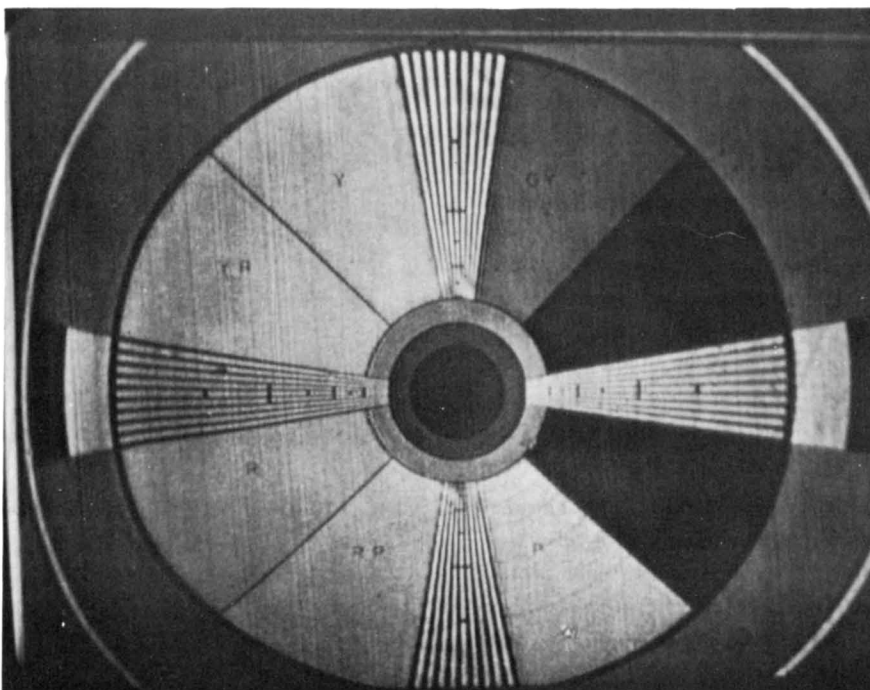

Fig. 12 - Photograph of a test pattern transmitted by a developmental Tricolor Vidicon similar to Fig. 11 except that the signal from only the red channel was displayed and photographed.



Fig. 13 - Photograph of a half tone color slide transmitted by the Tricolor Vidicon and displayed as in Fig. 11.

megacycles for the present target having 290 strips in each color. This frequency is not passed by the 3.5 mc video channel.

The finite number of strips results in a spurious moiré pattern in the vertical wedge of a test pattern. This effect has nothing to do with the scanning process but arises from an optical beating between the scene and the strips. Since the moiré pattern is different in each channel it may result in a faint spurious background color superimposed over the fine vertical bars in the test pattern. So far, this effect has not been considered objectionable in actual operation, even with scenes having considerable detail. If further experience should prove otherwise, targets can be made with more strips. Fig. 13 shows a half tone color picture photographed under the same conditions as Fig. 11.

#### Color Reproduction

The overall spectral response of each color channel can be measured by illuminating the face of the tube with monochromatic light. Measured response curves are plotted in Fig. 14. No correction was made for the high red content of the 2800 degree K incandescent light source used with the monochromator. The curves are only approximately equal to the product of the spectral response of the photoconductor and the transmission of the filters shown in Fig. 8. Of the total signal produced at any given wavelength, only a few percent appear in an improper channel. The slight dilution of color resulting from insufficient rejection of the unwanted color can be removed by elec-

trical masking, if necessary. Although provision for electrical masking was made in the test camera it has been found unnecessary with properly designed targets.

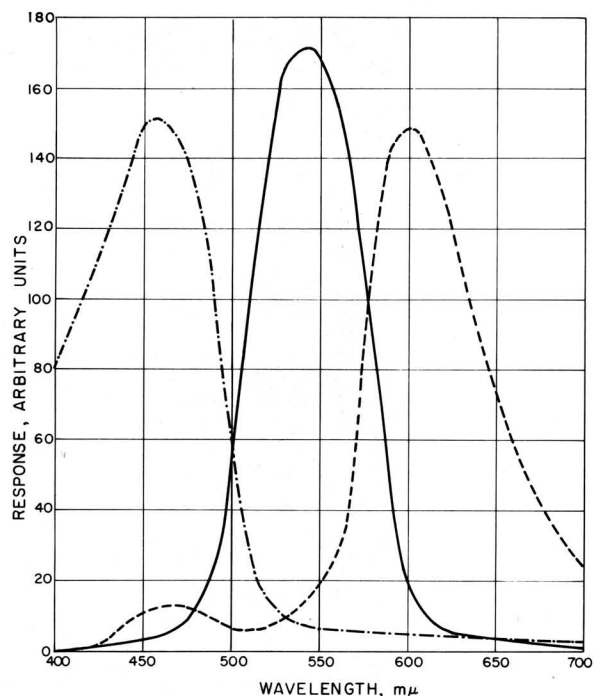

Fig. 14 - The overall spectral response of a developmental Tricolor Vidicon target obtained by illuminating the face of the tube with light from a monochromator and measuring the output of each preamplifier with an oscilloscope. (The ordinates were raised to the 1.4 power to correct for the less-than-unity gamma characteristics of the photoconductor)

*Sensitivity*

The operating sensitivity of any pickup tube depends to a large extent upon the characteristics of the photosensitive material. The photoconductive layer in the experimental tricolor Vidicon described here is a form of antimony sulfide, similar to that used in black-and-white Vidicons of the 6198 type.<sup>3</sup> This material has fairly high sensitivity for black-and-white operation when operated at high target voltages, but may, under certain conditions, exhibit an objectionable lag, or blurring of moving objects. The amount of lag depends upon the intensity of the light falling on the photoconductor; lower illumination gives relatively more lag.

The tricolor Vidicon requires substantially higher scene illumination than an equivalent black-and-white Vidicon because of the loss of light in the filters and, to a lesser extent, because of the increased noise level arising from the interstrip capacitance. There is also a greater tendency for lag because of the larger target area and the reduced intensity of the light reaching the photoconductor.

Developmental tricolor Vidicon cameras using antimony sulfide have been found to give pictures with a good signal-to-noise ratio and acceptable lag for motion picture film and slides, where ample light is available. For studio pickup their sensitivity is considerably less than three-tube image orthicon cameras. Although the tricolor Vidicon camera has been operated in the studio using an f-1.9 lens with 400 ft-candles incident illumina-

3. Vine, Janes and Veith "Performance of the Vidicon, A Small Developmental Television Camera Tube" *RCA Review* March, 1952.

tion, the resulting pictures have too shallow a depth of focus and too much lag for most broadcast purposes. Operation under these conditions would be practical, however, for many scientific and industrial applications. A more sensitive photoconductor having reduced lag would permit wider application of the tricolor Vidicon.

The present type of tricolor target could have been designed for use with a photoemissive surface rather than a photoconductive layer. More emphasis has been placed on photoconductive targets because they are believed to hold greater ultimate promise for satisfactory color pickup under adverse lighting conditions.

**Conclusions**

A new tricolor pickup tube capable of supplying three simultaneous color signals for use with the compatible color television system has been described. This type of tube is convenient to operate, has inherent image registry, and can be operated with simple equipment. Its present limitations in sensitivity restrict its uses to motion picture film, slides or industrial pickup. Sensitive photoconductors will eventually be developed and will permit wider application of this tube.

The tricolor Vidicon is still undergoing development and is not available commercially. Important factors, such as life and cost, although encouraging from a research point of view, cannot be properly evaluated at the present time.

*H.C. Thompson*

\_\_\_\_\_  
H.C. Thompson

*Stefan A Ochs*

\_\_\_\_\_  
Stefan A. Ochs

*Harold Borkan*

\_\_\_\_\_  
Harold Borkan

*Sidney Gray*

\_\_\_\_\_  
Sidney Gray

*Paul K. Weimer*

\_\_\_\_\_  
Paul K. Weimer