



REFLEX

C-BAND OSCILLATOR



VA-221A-G, K
5.860 to 7.850 kMc

VA-220A-G, Z
5.925 to 8.100 kMc

- Excellent Reliability
- Long Life
- Controlled Characteristics
- Low Noise
- Rapid Warmup
- Single Screw Tuner

The VA-220 and VA-221 series of reflex klystrons were developed primarily for local oscillator or low power transmitter operation in microwave relay systems. The VA-220 series provides approximately 1 watt of power for transmitters. The VA-221 series provides approximately 30 milliwatts for local oscillator application. The integral external cavity design insures excellent stability and is accurately tuned by a single screw tuner.

CHARACTERISTICS, VA-221C*:

Frequency.....	6.955		7.255		kMc
	Min.	Avg.	Min.	Avg.	
Power Output**.....	25	36	25	39	mW
Beam Voltage.....	—	300	—	300	Vdc
Beam Current.....	—	23	—	22	mAdc
Reflector Voltage.....	-75	-96	—	-111	Vdc
Bandwidth.....	25	33	25	39	Mc

*Similar characteristics for other tubes in the VA-221 series.

**VA-221A has a minimum power output of 20 mW.

CHARACTERISTICS, VA-220C:

Frequency.....	6.875		7.125		kMc
	Min.	Avg.	Min.	Avg.	
Power Output.....	700	950	700	1050	mW
Beam Voltage.....	—	750	—	750	Vdc
Beam Current.....	—	72	—	71	mAdc
Reflector Voltage.....	-250	-325	-250	-370	Vdc
Bandwidth.....	28	40	28	40	Mc

The minimum characteristics are the same for all tubes in the VA-220B to VA-220G group.

The minimum characteristics for the VA-220A are the same except bandwidth minimum is 25 Mc.

The minimum characteristics for the VA-220Z are the same except bandwidth minimum is 21 Mc and power output minimum is 500 mW.

MECHANICAL TUNING RANGE:

VA-221K.....	5.860 - 6.150	kMc	VA-220F.....	5.925 - 6.225	kMc
VA-221F.....	5.985 - 6.285	kMc	VA-220E.....	6.125 - 6.425	kMc
VA-221G.....	6.505 - 6.705	kMc	VA-220G.....	6.425 - 6.575	kMc
VA-221E.....	6.285 - 6.585	kMc	VA-220D.....	6.575 - 6.875	kMc
VA-221D.....	6.705 - 7.005	kMc	VA-220C.....	6.875 - 7.125	kMc
VA-221C.....	6.955 - 7.255	kMc	VA-220B.....	7.125 - 7.425	kMc
VA-221B.....	7.255 - 7.555	kMc	VA-220A.....	7.425 - 7.750	kMc
VA-221A.....	7.550 - 7.850	kMc	VA-220Z.....	7.750 - 8.100	kMc

The VA-220 klystrons are recommended replacements for the X-26 klystrons. In equipment where the effective resonator position is important, the VA-1120 adapter should be used.

C-BAND OSCILLATOR

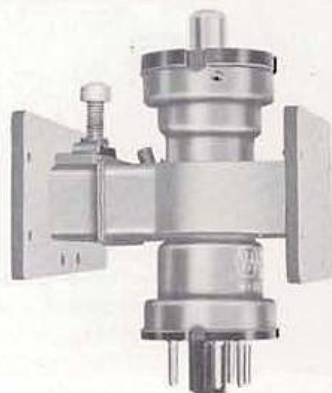

VA-222A-G, Z
5.925 to 8.100 kMc

- For Microwave Relay Transmitters
- Conduction Cooled

Identical electrically to the VA-220 A-G, and Z series of klystrons. Miniature rectangular output flange mates with CMR-137 flange. Conduction cooling eliminates need for blower.

H-BAND OSCILLATOR



VA-225A
7.5 to 8.5 kMc

VA-225B
7.0 to 8.0 kMc

VA-225C
7.0 to 8.0 kMc

- Conduction Cooled

The VA-225 klystrons are designed for use in line-of-sight relay communication systems in the Government band (7.125 to 8.500 kMc). Depending on resonator voltage used, these versatile tubes will provide either 1 watt or 100 milliwatts output in transmitters, or 30 milliwatts for local oscillator receiver service. Conduction cooling eliminates the need for a blower. The VA-225A and VA-225B mate with the UG-51/U flange. The VA-225C mates with the CMR-137 flange.

CHARACTERISTICS, VA-225A:

Frequency.....	7.5		8.5		kMc
	Min.	Avg.	Min.	Avg.	
Power Output.....	700	1450	700	1000	mW
Beam Voltage.....	—	750	—	750	Vdc
Beam Current.....	—	74	—	73	mAdc
Reflector Voltage.....	-250	-265	-250	-400	Vdc
Bandwidth.....	25	63	25	37	Mc
Power Output.....	100	375	100	285	mW
Beam Voltage.....	—	500	—	500	Vdc
Beam Current.....	—	40	—	39	mAdc
Reflector Voltage.....	-125	-150	-125	-245	Vdc
Bandwidth.....	25	55	25	35	Mc
Power Output.....	20	45	20	40	mW
Beam Voltage.....	—	300	—	300	Vdc
Beam Current.....	—	19	—	18	mAdc
Reflector Voltage.....	-50	-60	-50	-105	Vdc
Bandwidth.....	20	46	20	28	Mc