

Television transmitters for the ultra-high frequency band

J. A. van der Vorm Lucardie

621.397.61.029.6

A number of frequency bands in the very high and ultra-high frequency regions of the radio spectrum have been set aside by international agreement for the provision of television and sound broadcasting programmes. In these regions, which are generally referred to by their initials VHF and UHF, a total of five bands are available. Bands I, II and III are in the VHF spectrum and bands IV and V in the UHF. Band II is used for sound broadcasting, while the others have been assigned to television broadcasting.

For frequency-band allocation the world is divided into three regions, and the location of the frequency bands varies slightly for each of these regions. That for Europe, the Near East and North Africa was last defined in 1961 during the Stockholm conference^[1]. As the use of frequencies in UHF bands IV and V was still in a very early stage, it proved possible to define the bandwidth available per television channel — 8 Mc/s — and the positions of the vision carrier frequencies within bands IV and V in a uniform manner.

For the sake of completeness the positions of the five bands are here quoted:

- Band I : 41 — 68 Mc/s (7.3 — 4 m),
- Band II : 87.5 — 100 Mc/s (3.4 — 3 m),
- Band III: 162 — 230 Mc/s (1.85 — 1.3 m),
- Band IV: 470 — 582 Mc/s (64 — 51 cm),
- Band V : 582 — 960 Mc/s (51 — 31 cm).

It will be seen from this table that bands I and III are relatively narrow and they can therefore accommodate only a limited number of TV channels.

The service area of a television transmitter — i.e. the area in which the field strength is sufficient to ensure good picture quality — depends on the height of the aerial and is confined within a radius of approximately 35 miles (60 km) for powerful stations. The interference area, however, extends much further and therefore the distance between two transmitters which it is intended to operate on the same frequency has to be several hundred kilometres. It is consequently impossible, even in countries where there is only one television programme, to obtain a completely closed pattern of service areas, as is desirable in Europe, using only channels which are available in bands I and III. If this is to be achieved, a number of additional channels in the UHF spectrum are necessary.

In addition to this need, however, a far greater one has been created by the desire to transmit a second or even a third television programme. Fortunately, the much greater width of bands IV and V amply allows the demand to be met in these bands.

In designing television transmitters for the UHF range a number of problems are encountered which are more or less peculiar to these high frequencies. We shall devote particular attention to such points in the present article.

The power required for transmitters in bands IV and V

A certain minimum field strength is necessary to ensure a good-quality television picture. An increase in the field strength need not involve increasing the transmitting power but can also be achieved by arranging that the RF power is not radiated uniformly in all directions but strongly concentrated in the horizontal plane. A number of aerial designs are available for this. It is consequently customary, in describing television transmitters, to speak of their "effective radiated power", which is defined as the product of the power applied to the aerial and a factor dependent on the type or design of aerial employed. This factor is expressed in decibels and is called the aerial power gain.

When allowance has been made for the effective aerial height, the gain of the receiving aerial and the noise contribution of the receiver, it is found that the effective radiated power of a UHF station has to be approximately 10 dB higher than that of a VHF station for the same quality of reception. The effective radiated power of large stations in bands I and III being 30-100 kW, an ERP of 300-1000 kW is necessary in bands IV and V.

At the frequencies with which we are concerned here the limit of the service area more or less coincides with the optical horizon as seen from the aerial, which is therefore erected in as elevated a position as possible. The short wavelengths in bands IV and V make it possible to obtain much greater aerial gain than in bands I, II and III, while keeping the size of the transmitting aerial within economic bounds. The limit is determined by mechanical considerations. The maximum gain factor that can be attained is approximately 50. If, finally, allowance is made for

Ir. J. A. van der Vorm Lucardie is on the staff of N.V. Philips Telecommunicatie Industrie, Hilversum.

^[1] Final acts of the European VHF/UHF Broadcasting Conference, Stockholm, 1961, published by the International Telecommunication Union, Geneva.

the fact that very considerable losses occur in the coaxial cable connecting the transmitter and the aerial in its high position at band IV and band V frequencies, it is finally found that transmitter powers of 10-40 kW are necessary.

On the basis of this result Philips' Telecommunicatie Industrie first developed a 10 kW transmitter. This was followed by a 20 kW transmitter, while for smaller service areas a 2 kW transmitter is now also available. All of these are suitable for colour television. When necessary, double power can be obtained by connecting two transmitters in parallel. An advantage of this arrangement is that if one transmitter develops a fault, the transmission can continue without interruption, though at reduced power. We shall return to this point later.

General arrangement of a television transmitter

What is generally called a television transmitter is in fact a combination of two transmitters, one of which transmits the vision signal and the other the accompanying sound signal. As the aerial and its feeder cable form a very costly element, both transmitters are always connected to the same aerial by means of a coupling network, for which the term combining unit has been generally adopted in television practice. The combining unit prevents the sound-transmitter and vision-transmitter from interacting on each other.

The essential parts of a vision-transmitter are shown in *fig. 1*. A crystal oscillator *A* generates a signal whose frequency is a sub-multiple of the transmitting frequency. The transmitting frequency is attained by multiplication in stage *B*. In *C* the radio-frequency signal is modulated by the video signal, which has previously been amplified in the video modulator *E*. As a rule, modulation takes place as close as possible to the output stage, and sometimes in the output stage itself. The effect of this is to simplify transmitter tuning and improve the stability. In output stage *D* the modulated signal is amplified to output level.

Amplitude modulation is used for picture transmission. The bandwidth occupied is limited by suppressing a large part of the lower sideband of the modulated signal. In television transmitters in which modulation is effected in the output stage, the general practice is to have the output stage followed by a filter combined with the combining unit. This combination

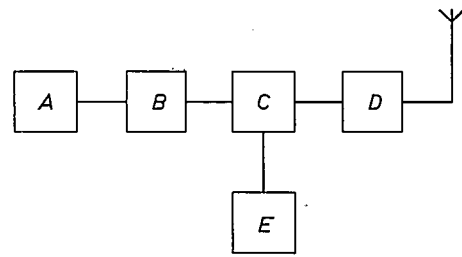

Fig. 1. Diagram showing the main parts of a vision-transmitter. *A* crystal oscillator; *B* frequency multipliers; *C* modulated amplifier; *D* final amplifier; *E* video modulator.

is called a filterplexer. In the transmitter to be described below, a combining unit is adequate since a klystron is used as the final power amplifier. Suppression of the lower sideband is effected with a simple coaxial filter inserted before the final amplifier input.

In keeping with normal practice, the sound-transmitter employs frequency modulation. Once again, the process starts with the generation of a signal with a frequency much lower than the transmitting frequency. This is done in the oscillator *A*₁ (see *fig. 2*), whose frequency is directly modulated with the sound signal, the latter being amplified in *F*. Oscillator *A*₁ cannot therefore be crystal-controlled and as a result its stability is limited. If the frequency of *A*₁ were to be raised to its final value solely by multiplication, as is done in the vision-transmitter, the large multiplication factor required would result in equally large magnification of the fluctuations of the mean frequency of oscillator *A*₁ in relation to its nominal value. The output frequency from *A*₁ is first doubled in *V*₁ and then compared with the frequency of a crystal oscillator *A*₂ in circuit *C*. This comparison circuit delivers a control voltage which corrects the mean frequency of *A*₁ when deviations are observed. Stage *V*₂ triples the output frequency of *V*₁ and the output signal from *V*₂ is then mixed in stage *M* with that from a crystal oscillator *A*₃ whose frequency is equal to half the mean transmitting frequency, minus the output frequency of *V*₃. The frequency of the output signal from *M* is therefore — after the suppression of unwanted products of mixing — half the mean trans-

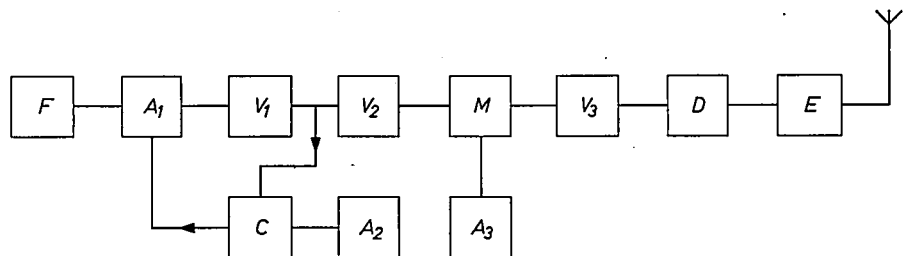

Fig. 2. Diagram showing the main parts of an FM sound-transmitter. *A*₁ frequency-modulated oscillator; *F* sound-amplifier/modulator; *V*₁ doubler; *C* comparison circuit; *A*₂ crystal oscillator; *V*₂ tripler; *M* mixer circuit; *A*₃ crystal oscillator; *V*₃ doubler; *D* power amplifier; *E* output amplifier.

mitting frequency. The transmitting frequency is finally attained in a doubler V_3 , which is followed by the power amplifier D and the output stage E .

As we have already observed, the sound-transmitter operates in the same frequency band as the vision-transmitter, and therefore the design problems raised by the two are largely the same. There are, however, two problems which are peculiar to the vision-transmitter and owe their origin to the fact that its power is approximately five times that of the sound-transmitter and that the bandwidth it requires is several Mc/s, compared with the few kc/s needed for the sound-transmitter. In the description which follows, we will therefore confine our observations to the vision-transmitter.

At the high frequencies of bands IV and V the choice of transmitting valves for the output amplifier constitutes a problem, at least for output powers of 10 to 20 kW. We will begin by examining this point.

Transmitting valves for the output stage of the vision transmitter

In the final amplification stage of their band I and band III transmitters, Philips generally use tetrodes in push-pull connection. At frequencies in the UHF range, two difficulties arise. In the first place the wavelength at these frequencies is comparable with the dimensions of the components used. To avoid unwanted radiation and coupling effects which can result in various types of instability, one must use coaxial techniques, in which the advantages of the simple design of the push-pull circuits are lost. This also means, however, that the full transmitting power can be attained much more simply with one valve than two.

A second feature is that at frequencies in the UHF range the electron transit time leads to incorrect valve operation. We shall not analyse this phenomenon here but merely point out that it greatly reduces the efficiency and power output of tetrodes. The obvious remedy for it is to make the electrode spacing as small as possible. There is, however, a limit to this reduction because, particularly in the case of valves for power of 10 kW and more the thermal demands on the material become greater and greater. This drawback can be partly overcome by replacing the glass by a ceramic insulator but even then the limit of what is possible is still reached sooner or later in large valves.

In the transmitter under discussion use has accordingly been made of klystrons or velocity-modulation tubes. The operating principle of the klystron has been described in numerous publications, including previous articles in this journal [2], and will therefore

not be discussed here. We will merely remind readers that in this type of valve a beam of electrons is passed through a cylindrical chamber which is interrupted by gaps at, basically, two places. If an a.c. voltage is applied across the first gap that the electron beam traverses, a velocity modulation of the electrons occurs which leads to a density modulation of the electron beam after the electrons have travelled a certain distance in the valve. If the dimensions of the valve are chosen so that the area where this density modulation is greatest coincides with the location of the second gap, energy can be drawn from the electron beam by loading this gap with a tuned circuit. The r.f. power thus obtained is many times greater than that needed to maintain the modulation voltage across the first gap, so that the valve can operate as an amplifier.

The amplifying effect can be increased further by arranging a number of gaps one after the other and bridging each gap with a tuned circuit. The Philips 11 kW klystron type YK 1001, used in the 10 kW transmitter, and the 22 kW klystron type YK 1061, used in the 20 kW transmitter, have four gaps and four circuits in the form of resonant cavities, and are sometimes called four-cavity klystrons. For the frequencies for which these klystrons are used the gaps are so spaced that both valves are about 5 ft. 6 in. long.

Before deciding whether klystrons or normal triodes or tetrodes are to be preferred for the frequency range in question, a number of considerations relating to design, operation and economy must be taken into account. From a design view point the very considerable power gain of the klystron has the advantage that the number of power amplifiers which precede it can be greatly reduced. This means that, despite the large dimensions of the klystron, the overall dimensions of a klystron transmitter need not be greater than those of a transmitter equipped with triodes or tetrodes.

Operationally, it is of great importance to be able to predict impending klystron failure, as will be seen below. This enables the klystron to be replaced before it fails, thus eliminating the risk of failure during a broadcast and consequent interruption of the programme. The fact that it takes much more time to replace a klystron than the much smaller triodes and tetrodes is, by comparison, of secondary importance. There is often no means of predicting the end of the life of the latter type of valves with any certainty and the possibility of their failure during a broadcast cannot be disregarded. In view of the pre-

[2] See, for example, B. B. van Iperen, Velocity-modulation valves for 100 to 1000 watts continuous output, Philips tech. Rev. 13, 209-222, 1951/52.

Fig. 3. Photograph of the type YK 1001, four-cavity klystron without focusing magnets or resonant cavities. The getter ion-pump is visible at the top of the valve.

←

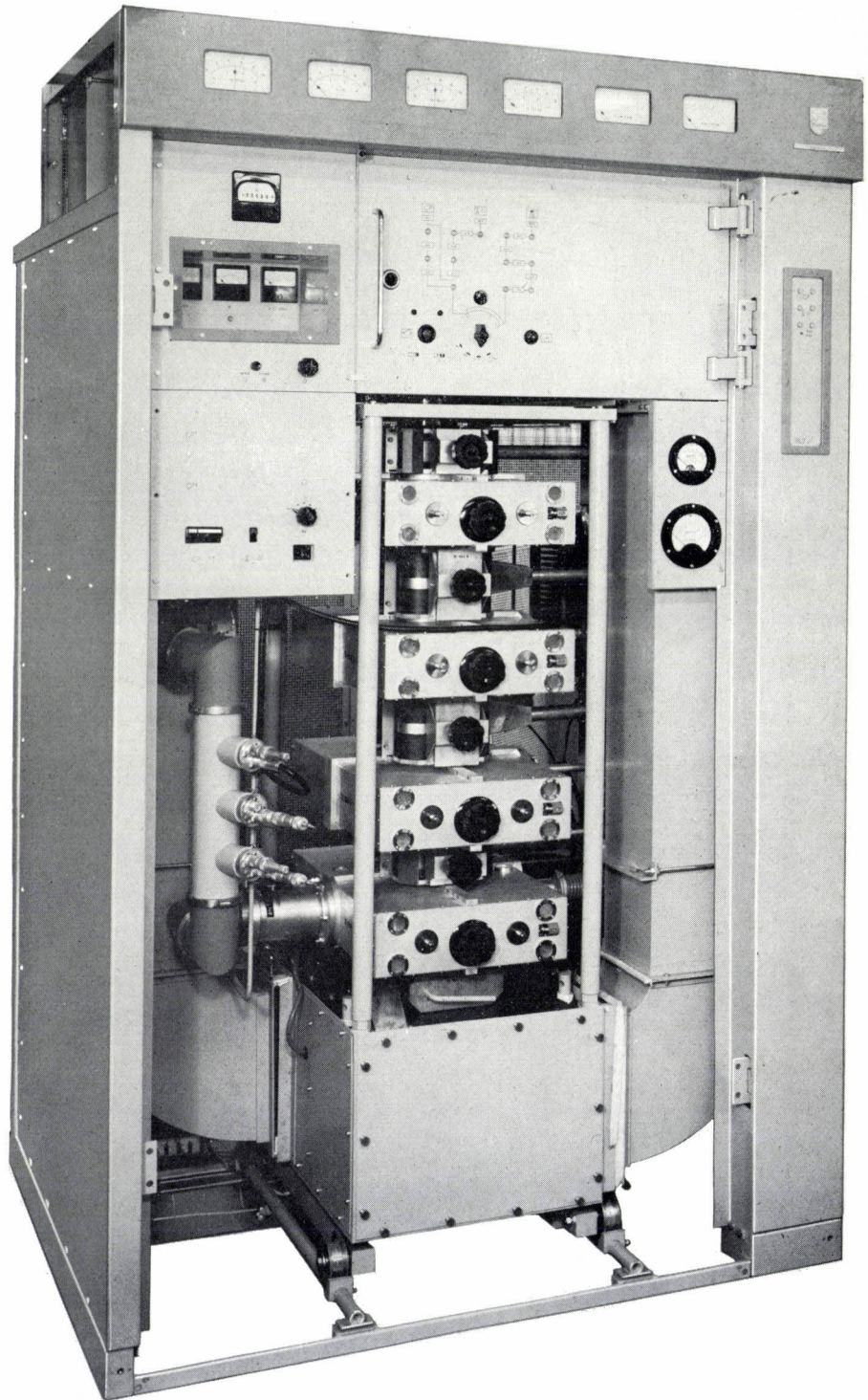
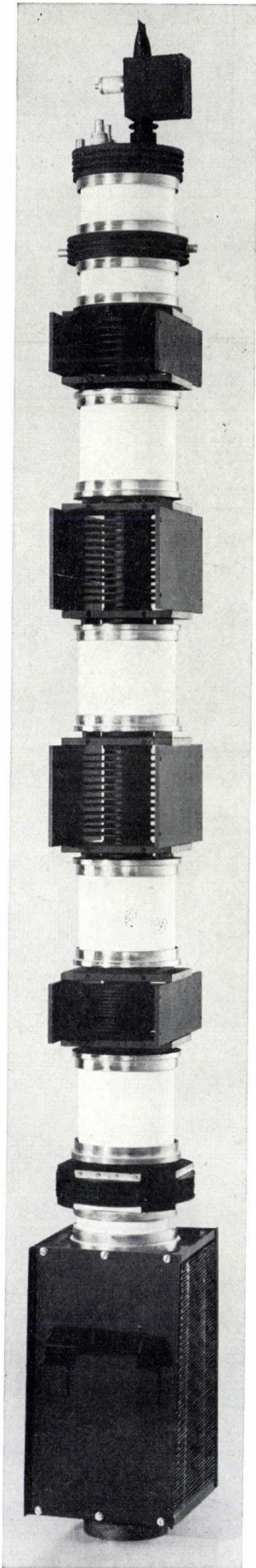

Fig. 4. Arrangement of a type YK 1001 klystron in the output stage of the 10 kW vision-transmitter.

sent trend towards television stations which are not permanently attended, the time involved in travelling to and from the transmitting station is of far more consequence than the time required to change the valves. It is therefore preferable that such changes should be made in the course of routine maintenance visits.

The fact that klystrons have a much longer life than tetrodes economically outweighs the lower purchase price of tetrodes. With regard to the power consumption of a klystron transmitter, the efficiency of a klystron operated as a class A amplifier can be considerably improved by appropriate measures, which will be discussed in greater detail below. This and the fact that the total number of amplification stages can be smaller in a klystron transmitter mean that the overall efficiency of a klystron transmitter is not inferior to that of a transmitter equipped with tetrodes, although the tetrodes themselves, being connected as class B or class C amplifiers, are themselves more efficient than the klystron.

As already observed, a large part of the lower sideband of the amplitude-modulated vision-transmitter carrier has to be suppressed. It is an advantage of the four-cavity klystron that the gain of the valve can be made markedly selective — a point to which we will return — so that the filter inserted in the circuit prior to the modulated stage can be simplified still further.

Thus, although from the point of view of design and economy the advantages of klystrons approximately balance those of triodes and tetrodes, the reliability of the klystron transmitter seems to tip the balance in its favour, and it was this consideration which determined the principle adopted in the Philips 10 kW and 20 kW transmitters.

The type YK 1001 klystron

As the design principles embodied in the construction of the type YK 1001 11 kW and type YK 1061 22 kW klystrons are very similar and the klystrons have practically identical dimensions, it will suffice here to describe a number of details of the YK 1001.

Fig. 3 shows this valve without the accessories that are visible in *fig. 4*, which is a photograph of the same valve arranged in position in the output stage of the 10 kW transmitter. The valve is best described with reference to *fig. 5*, which combines a diagram of a section through the klystron with the circuit in which the various components of the valve are included.

The electron beam traversing the entire valve in the longitudinal direction is provided by an impregnated cathode [3]. The life of this very ruggedly constructed type of cathode is favourably influenced here by the fact that the cathode is clear of the regions in

which high-frequency alternating fields occur, and this enables the cathode to be given ample dimensions.

The cathode has a concave emitting surface, so that the electrons emerging from it are already beamed to some extent; the focusing electrode which the electrons now pass and which has a negative potential of about 300 V relative to the cathode, ensures that the electrons are sharply beamed before they enter the valve proper. Before this happens they also pass an accelerating anode which, like the walls of the valve, is at earth potential. As the cathode is maintained at approximately -18 kV, the electrons enter the drift space at full velocity.

On leaving the transit region, the electrons encounter the collector. As will be seen from the diagram, the latter has a voltage of about -5 kV relative to the wall of the drift space region. The result is that the electrons, on leaving the last section of the drift space, are decelerated and arrive at the collector with reduced velocity. In this way a portion of the energy imparted to the electrons during their acceleration is recovered and the efficiency is improved.

When the depth of modulation is large, some electrons will already have a low velocity on leaving the drift space. To prevent these electrons from going only part of the way to the collector and returning to the last section of the drift space, the collector is shaped so as to impede these returns as much as possible.

Although the electrons, on entering the drift space, are concentrated by the operation of the focusing electrode, the beam will tend to disperse again owing to the repelling effect of the electrons on each other. The length of the drift space in relation to its width is so large that if no countermeasures were taken some of the electrons would strike the wall of the drift space, eventually causing excessive heating of the klystron wall. It is therefore necessary to maintain a focusing effect along the entire length of the beam. The most economical means of doing this is by using an axial magnetic field. As the beaming effect is independent of the direction of the field, so long as the latter is axial, it is permissible to use either a field which has a fixed direction over the length of the klystron or a field that reverses its direction several times along the axis of the valve.

In the earliest klystrons to appear on the market a field of constant direction was employed which was generated by a number of circular coils surrounding the klystron. As will be seen in *fig. 4*, such coils do not figure in the YK 1001 klystron. They have been replaced by a number of permanent magnets made of ferroxdure. It can be shown [4] that by employing an alternating field (i.e. alternating in space but not in time) which is generated by a number of small, per-

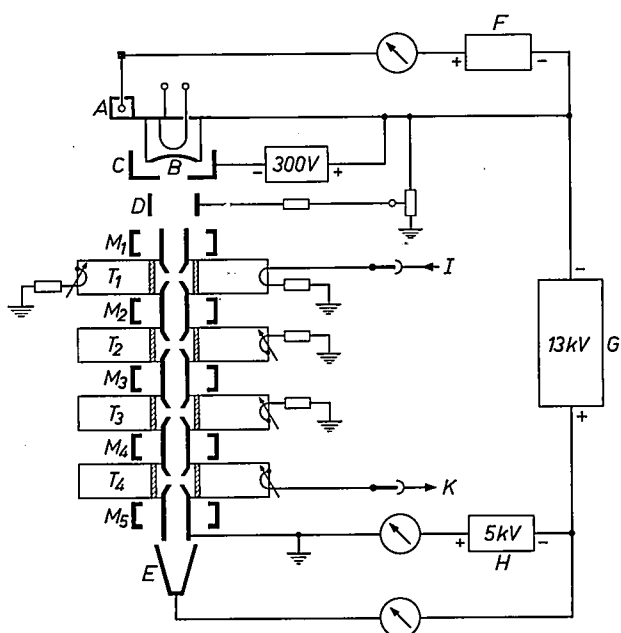

Fig. 5. Combined cross-sectional drawing of the type YK 1001 klystron and diagram of the circuit in which it is used. A ion pump; B cathode; C focusing electrode; D acceleration anode; M_1 to M_5 focusing magnets; T_1 to T_4 resonant cavities; F power supply rectifier for the ion pump; G 13 kV HT rectifier; H 5 kV HT rectifier; I RF signal from preceding stage; K output signal to aerial.

manent magnets, it is possible to save considerably on magnetic material compared with an arrangement whereby a field of fixed orientation is set up with a single large magnet. The use of permanent magnets also means a saving in weight by comparison with the use of magnetic coils. Of even more importance, however, is the fact that the klystron, being no longer surrounded by coils is freely accessible.

The beaming effect obtainable with a magnetic field of alternating direction does not manifest itself until a certain minimum value of the beam voltage^[4] is reached. The cathode voltage is therefore brought to its full value at once and then the beam current is increased by means of the accelerating anode. When the HT rectifier is switched on, the voltage control of the accelerating anode is set so that this anode is at cathode potential. Then the accelerating anode is brought to earth potential in steps.

Despite the very careful degassing to which transmitting valves are always subjected, it is necessary to allow for the possibility that when the klystron is being put into service, and to a lesser degree when it is in actual operation, residual gas may be released from various components. The presence of small amounts of gas has a harmful effect on the life of the cathode and on the operation of the valve as a whole. The klystron therefore has a permanently fitted getter ion pump. As fig. 3 shows, this pump is a small cube-shaped box mounted at the top of the tube. It also

serves as a vacuum gauge, operating on the principle indicated by Penning^[5], with which the vacuum can be measured not only before the valve is put into service but also while it is in operation. The former possibility is important because klystrons have a life of many thousands of hours and consequently the spare valves which have to be kept in reserve at every transmitter are sometimes held in store for a long time before they go into use. A very tiny leak which cannot be detected during manufacture may have reduced the vacuum considerably during that period, without by any means having rendered the valve unsuitable for use, because the ion pump can easily extract the small quantity of gas that has entered. If any deterioration is measured, the pump is switched on for a time before the valve is put into operation.

Regular measurement of the vacuum during operation gives a check on the condition of the valve, thus making it possible to ensure that the valve does not fail at an undesirable moment, e.g. while the transmitter is on the air. This, and the regular check on the condition of the cathode provided by measurement of the beam current, make it practically certain that a broadcast need never be interrupted by the failure of a klystron.

Tuning the output stage

It will be seen from fig. 3 that to maintain the vacuum, the modulation gaps in the valve are bridged by ceramic sleeves. As these sleeves are in the r.f. alternating field, the material of which they are made must satisfy very stringent requirements. The material chosen is an aluminium oxide ceramic.

These sleeves are not visible in fig. 4, being enclosed in the resonant cavities bridging the modulation gaps. Each of these cavities takes the form of a rectangular box fitted round the tube in two halves. One such half is shown in fig. 6. As can be seen from the photograph, one of the walls of the box is adjustable and thus can be used to tune the cavity to the desired frequency. The photograph also shows an adjustable coupling loop. A loop of this kind is used in the first resonant cavity (T_1 in fig. 5) to inject the RF power excitation needed. In cavities T_2 and T_3 the loop is used to couple an external load resistance to the RF field. Adjustment of the coupling loops and tuning of the resonant cavities together give the desired form of tuning charac-

^[3] R. Levi, Dispenser cathodes, III. The impregnated cathode, Philips tech. Rev. 19, 186-190, 1957/58.

^[4] J. T. Mendel, C. F. Quate and W. H. Yocom, Electron beam focusing with periodic permanent magnet fields, Proc. IRE 42, 800-810, 1954.

^[5] F. M. Penning and K. Nienhuis, Construction and applications of a new design of the Philips vacuum gauge, Philips tech. Rev. 11, 116-122, 1949/50, and A. Klopfer and W. Ernrich, A small getter ion-pump, Philips tech. Rev. 22, 260-265, 1960/61.

teristic. The coupling loop in the last cavity, T_4 , is used to take the RF power from the klystron.

It can be seen in *fig. 7* that the resonance frequencies of the various cavities do not coincide with the car-

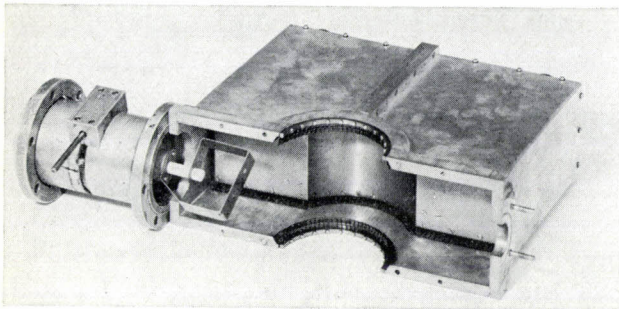

Fig. 6. One half of a box-shaped resonant cavity. One wall can be adjusted to tune the cavity. An adjustable coupling loop can be used to inject or extract RF power.

rier frequency. The flatness of the resonance curves of cavities T_1 , T_2 and T_3 can be modified by increasing or decreasing the resistive load on the cavities by means of the coupling loops. The flatness of the curve of cavity T_4 is of course determined by the aerial load. The result of connecting in tandem the four circuits tuned in this way is shown at the bottom of *fig. 7*.

The range of frequencies over which the resonant cavities can be tuned extends from 470 to 790 Mc/s. The same klystron can also be used for the band V top frequencies, up to 960 Mc/s, but a second set of resonant cavities is then necessary.

The driver stages

Our discussion of the driver stages will be restricted to the stage immediately preceding the klystron — i.e. where modulation takes place — and to the modulation amplifier. The penultimate stage of the transmitter is driven by a signal at carrier frequency. The amplifier valve used in it is the type YL 1100 tetrode. The circuit of which this valve forms part is reproduced in *fig. 8*, which also shows part of the physical construction. The modulator circuit can also be seen in the diagram.

To increase the stability of the amplifier the grounded-grid circuit has been chosen, with a tuned circuit inserted between grid and cathode and another between the grid and anode. The grid has a d.c. connection to earth. Both tuned circuits, as *fig. 8* shows consist entirely of concentric conductors.

Conductors a and b form a coaxial system through which the filament voltage is connected to the valve. The space inside conductor b is therefore free of RF fields. Conductors b and c together constitute the grid-cathode circuit. At the top, the grid-cathode capacity terminates the coaxial line formed by b and c . A variable capacitor at the other end of this coaxial line is used to adjust the grid-cathode voltage to a maximum.

Cylindrical can d forms a cup over the top of conductor c : the space between the two forms the grid-anode circuit, which is tuned with a piston fitted in the lower part of the box d . The cover top of can d is removable, so that the valve is accessible for replacement. All connections to the electrodes of the valve are made by means of circular arrangements of spring contacts and replacement is therefore a simple operation.

The banks of spring contacts for both the screen-grid, anode, and control-grid connections are mounted on flat metal rings. The ring for the control grid contacts is fixed to the top of conductor c . This ring and the one for the screen-grid contacts, which is fitted on top of it, are separated by a mica ring. The capacitance

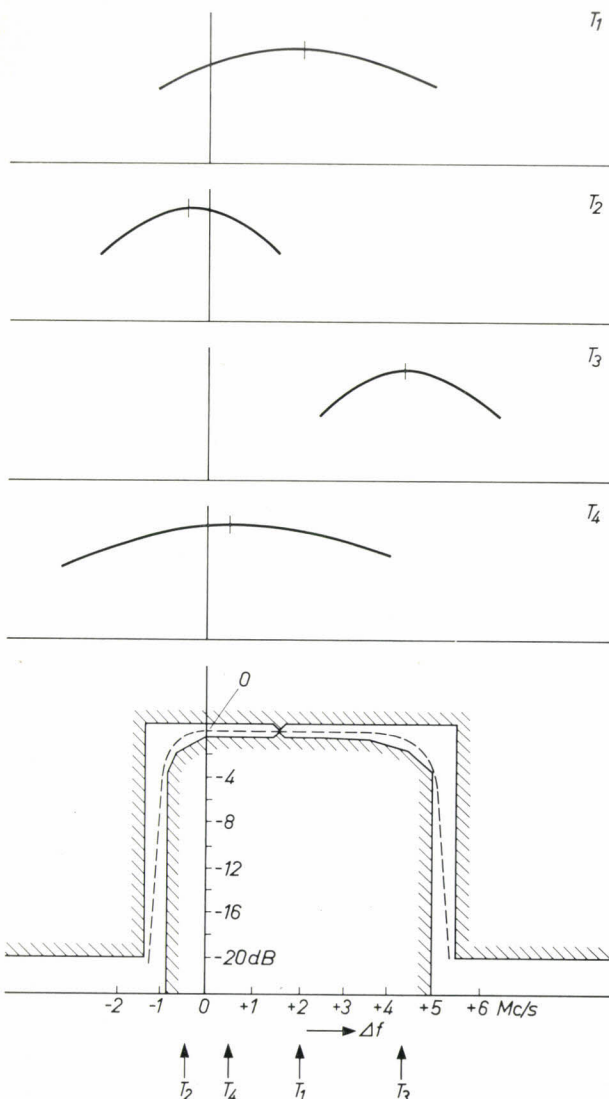

Fig. 7. The resonant cavities are tuned so that the maxima of the amplitude-frequency response curves for the various resonators are slightly to the side of the nominal carrier frequency. The overall gain characteristic of the klystron is therefore as shown at the bottom of the figure.

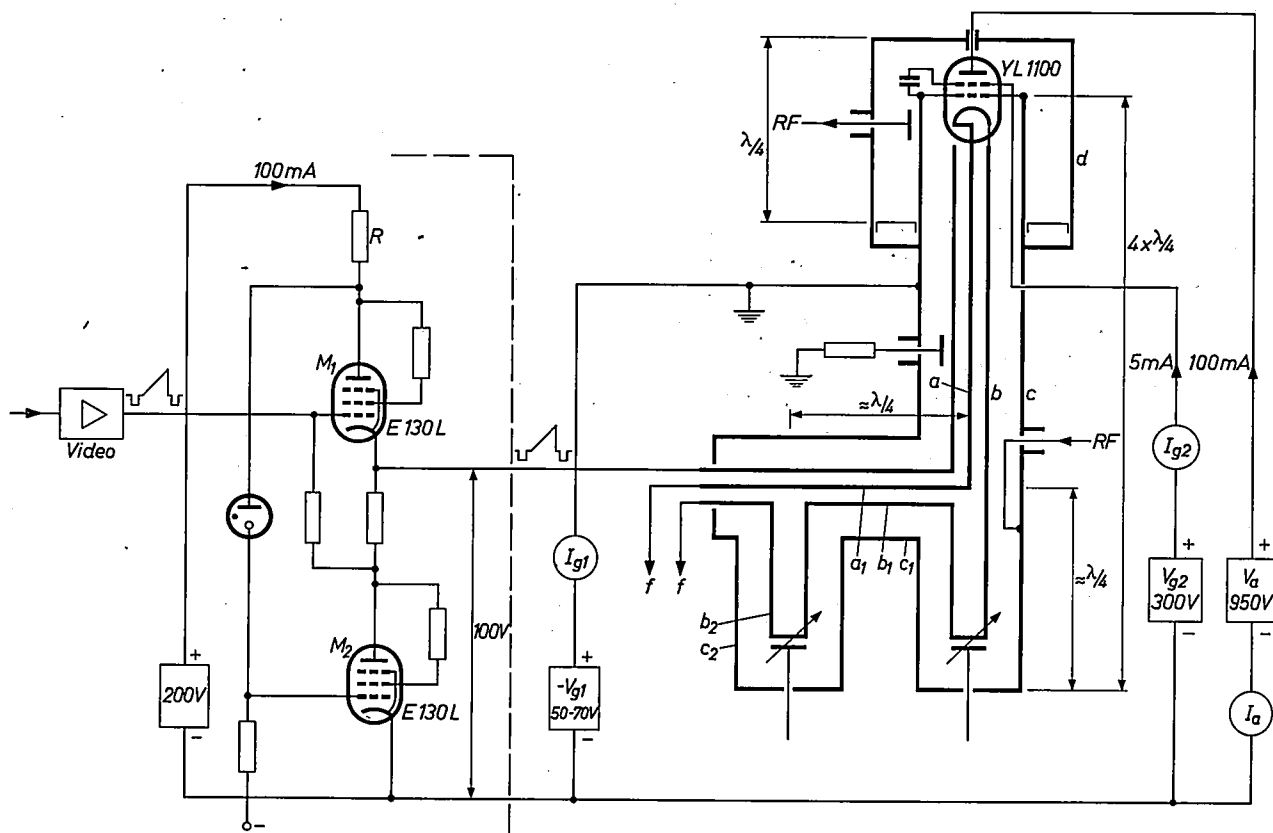

Fig. 8. Circuit diagram of the penultimate amplification stage of the video transmitter and the modulator. M_1 modulator valve; M_2 cathode impedance valve for M_1 ; a - b coaxial pair via which the heater voltage is taken to the YL 1100 valve; b - c coaxial cavity between the grid and cathode of the YL 1100 valve; b_1 - c_1 quarter-wave line to coaxial cavity b_2 - c_2 , forming a short-circuit for the transmitting frequency and preventing the r.f. voltage from getting into the modulator.

thus created keeps the r.f. potential of the screen grid the same as that of the control grid, while the two d.c. potentials differ. A similar arrangement ensures that the anode d.c. voltage can be connected to the valve without d.c. connection with the box.

As we have already said, the transmitter has to be tunable over the frequency range 470 to 790 Mc/s. The length of conductors b and c is chosen in such a way that the system is electrically approximately a whole wavelength long for the frequency in use and consequently there will be voltage antinodes at the extremities of b when the transmitter is correctly tuned. About a quarter wavelength from the lower end there will be a voltage node — and hence also a current antinode — and it is here, at one side, that the coupling loop is fitted via which the grid-cathode circuit is excited by the preceding amplifier stage. At the top end the r.f. power is drawn from the anode circuit with the aid of a capacitive coupling.

Opposite the coupling loop, there is a branch system comprising conductors a_1 , b_1 and c_1 . The video modulation voltage is applied to the amplifier tube via conductor b_1 . To ensure that no r.f. power finds its

way into the modulator via b_1 , another branch b_2 - c_2 is fitted about a quarter wavelength from the centre of b - c . At the end of this branch there is a variable capacitor which can be adjusted so that circuit b_2 - c_2 assumes a condition of series resonance. The branch then in effect sets up a short-circuit at the point of connection, thus preventing r.f. power from entering the modulator.

The modulator amplifier

The extremely high power of the klystron means that an r.f. driving power of only 15 W is needed to ensure the full output power of 10 kW. The klystron is connected as a linear amplifier and modulation takes place in the stage which precedes it.

As the r.f. amplifier in fig. 8 operates in a grounded-grid connection, it is not modulated at the grid, but at the cathode. This means that the cathode current of the YL 1100 valve has to be furnished by the modulator but, as this current is only 100 mA, no difficulty arises.

The cathode-grid impedance of the YL 1100 tube forming the load on the modulator output varies con-

siderably with the amplitude of the modulation voltage. To reduce this effect the grid-cathode circuit is loaded by an external fixed resistor which is capacitively coupled to conductor *b*. Nevertheless, the output impedance of the modulator still varies too much to make special measures unnecessary. These measures are designed to reduce the internal resistance of the modulator as far as possible, for only then can a sufficiently linear amplitude response be obtained with variable load.

As can be seen from fig. 8, modulator tube M_1 , for which a type E 130 L pentode has been chosen, is connected as a cathode follower. The anode impedance of valve M_2 — also an E 130 L — whose grid is coupled to the anode of M_1 , acts as a cathode resistance. Careful design of this negative feedback circuit enabled the internal resistance of the modulator to be reduced to a very low value, measurement showing it to be less than 4 ohms.

Sideband suppression

The video signal has a bandwidth of approximately 5 Mc/s. The amplitude modulation of the vision-transmitter produces two sidebands, one on either side of the carrier frequency, so that a total bandwidth of 10 Mc/s is occupied. It has been agreed internationally to suppress a large part of the lower sideband to save space in the frequency spectrum. In bands I and II, where 7 Mc/s is available per channel, this sideband is cut off in accordance with the curve shown schematically in fig. 9. The curve is flat to 0.75 Mc/s below the carrier frequency and reaches zero at a point 1.25 Mc/s below it.

The curve shown in fig. 10 has been adopted as a standard for the r.f. amplitude response of television receivers. It begins to drop 1 Mc/s above the transmitting frequency f_z and reaches the zero line 1 Mc/s below it. Nevertheless, it can be avoided if, as in fig. 11, the transmitter response is not allowed to drop until the frequency is 1 Mc/s below the carrier. This solution is a possibility in bands IV and V, because of the extra space available.

Partial suppression of the lower sideband introduces phase errors into the video signal, and the steeper the slope of the transmitter response curve, the greater these errors will be. Phase errors are also present in the receiver. For economic reasons these are corrected in the transmitter. The phase correction usually is essentially a pre-distortion of the video signal. When sudden level variations take place in the video signal,

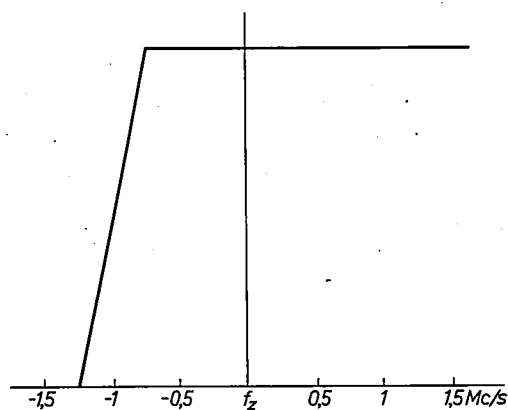

Fig. 9. The lower-frequency end of the amplitude-frequency response curve of the vision-transmitter, shown diagrammatically. The response is flat to 0.75 Mc/s below the transmitting frequency f_z , falling to zero at 1.25 Mc/s below f_z .

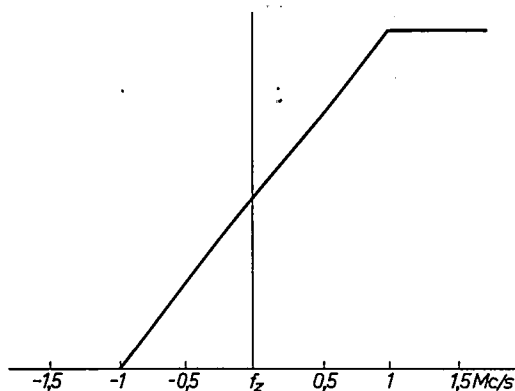

Fig. 10. The amplitude response curve of the average television receiver. It begins to drop 1 Mc/s above the transmitting frequency f_z and reaches the zero line 1 Mc/s below it.

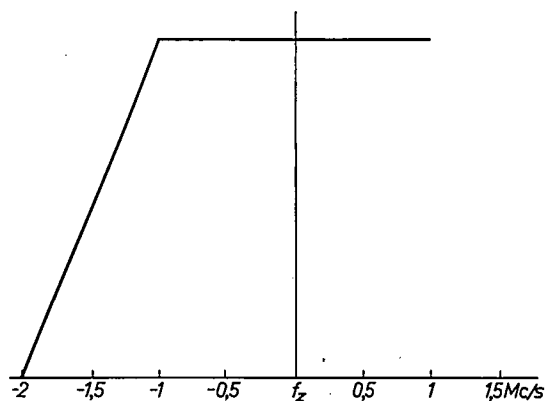

Fig. 11. The Philips vision-transmitter can be tuned so that the residual sideband characteristic of the transmitter assumes the form seen here. In combination with the receiver characteristic shown in fig. 10 it gives an overall response which is entirely flat.

pre-distortion causes this signal to "overshoot", i.e. there is for a moment a larger variation in level than that warranted by the actual signal. This means that a sudden change from white to black causes temporary overmodulation of the transmitter. As a bandwidth of 8 Mc/s is available in bands IV and V, the response curve can be given a gentler slope in these bands, so

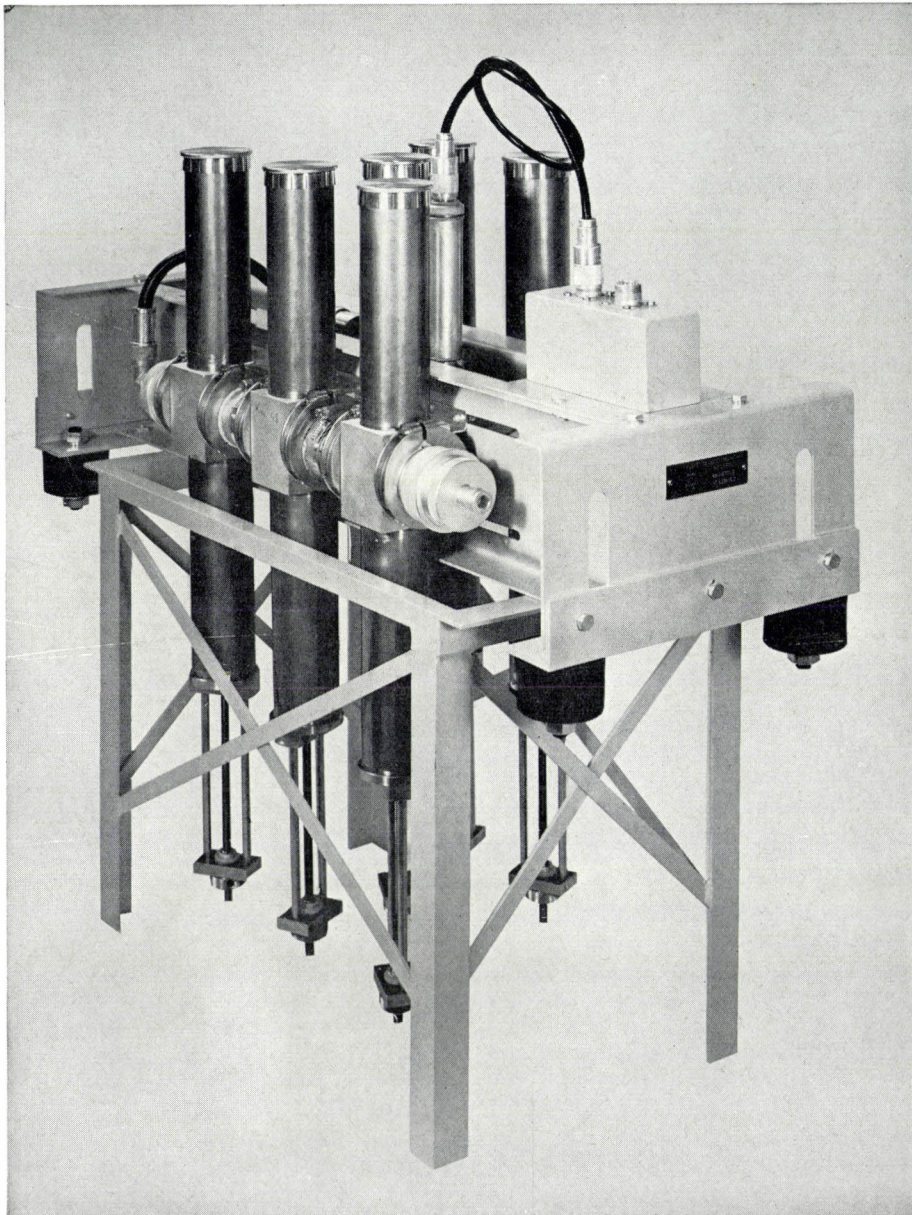

Fig. 12. The component parts of the Nyquist receiver are mounted on a frame. In front, the Nyquist filter; behind it, the notch filter; in between, the detector, and, on the right, the phase correction filter.

to a crystal detector via a pair of filters which will be described below. This arrangement not only enables the number of electrical components to be kept down, but it also obviates the use of amplifier valves which, as they age, become an important contributory cause of response curve drift in receivers.

The signal to be monitored passes through a high-pass filter, a band-rejection filter, a detector and a phase-correction filter, in that order. The first two filters determine the amplitude-frequency response of the receiver and must therefore satisfy high standards of stability. They are composed of coaxial elements which, to eliminate the effect of temperature variations on the characteristics, are made partly of Invar. Both filters are accurately adjusted for the

transmitter frequency chosen and must therefore be replaced if this frequency is changed.

that the phase distortion is decreased and less phase correction is needed. The bands IV and V transmitter described here can be adjusted to give a residual-side-band response like that shown in fig. 11.

Monitoring the transmitted picture signal

The first filter, which is used to give the amplitude-frequency response curve the lower-end slope shown in fig. 10, is a high-pass filter generally referred to as the Nyquist filter. The second is a band-rejection filter for preventing the sound transmitter signal, which, of course, is also present in the transmitter output lead, from entering the receiver. This type of filter is known in television engineering as a notch filter. The two filters are mounted on a chassis together with the crystal detector and phase correction filter, as shown in fig. 12.

Monitoring the transmitted picture signal

For adjustment of the transmitter and regular supervision of the transmitted vision signal it is necessary to have a monitoring receiver with an amplitude response which is exactly as shown in fig. 10. As this response curve was first indicated by Nyquist, this receiver is generally referred to as a Nyquist demodulator. Because of the important task this receiver performs, its response curve must not vary. As the input signal to the receiver can be taken straight from the transmitter output, sufficient power is available for the signal to be applied without pre-amplification

In both the Nyquist filter and the notch filter the r.f. signal is fed in via a coaxial line which has shunt coaxial stubs at quarter-wavelength intervals. These stubs are clearly visible in fig. 12. A cross-section of

a stub is given in *fig. 13*; lengths l_1 and l_2 and capacitor C are variable for adjustment purposes.

When the design of the stubs was being determined, it was found that the exact formulae involved calculations which were practically impossible

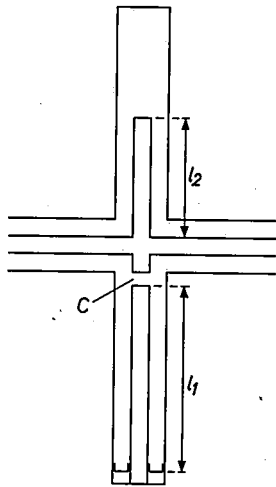

Fig. 13. Schematic cross-section through a coaxial stub as used in the two r.f. filters of the Nyquist receiver.

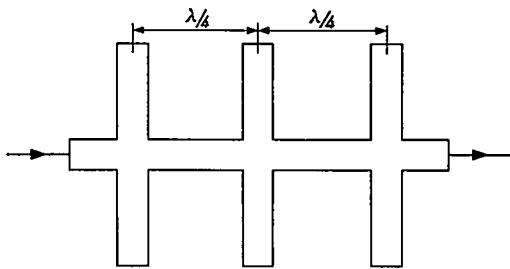

Fig. 14. In the Nyquist filter three coaxial stubs are fitted at intervals of a quarter wavelength along a coaxial line.

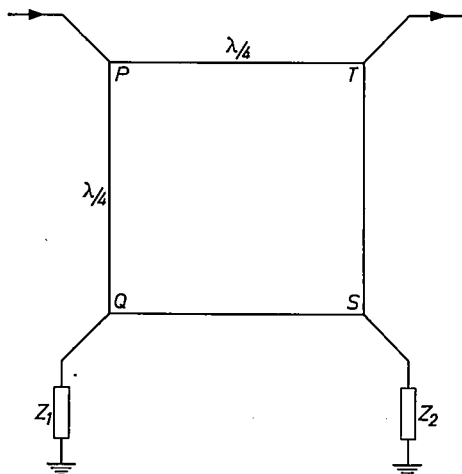

Fig. 15. Schematic diagram of the bridge circuit used in the notch filter.

to perform. Use was made therefore of the fact that the behaviour of the admittance of the stubs in the significant range of frequencies is very closely approximated by that of a circuit consisting of a capacitor and an inductor in series, with an inductor or capa-

capitor connected in parallel. The approximate values thus found for the practical dimensions could then be checked with the exact formulae.

The design of the Nyquist filter is shown schematically in *fig. 14*. The notch filter, whose function is to keep the vision signal free of interference from the sound signal, must present an attenuation of 40 dB at the sound carrier frequency. If this filter were designed on the same lines as the Nyquist filter, it would not be possible to ensure the desired attenuation with the circuit Q attainable at the frequencies concerned. This is, however, possible with the bridge circuit shown in *fig. 15*. The bridge consists of a closed system of four coaxial lines which are in principle each a quarter wavelength long. The input and output are at two adjacent corners of the bridge, while impedances Z_1 and Z_2 , which take the form of coaxial stubs of the same type as used in the Nyquist filters, are connected to the other two corners. Although the elements used have a finite Q , the bridge circuit enables the same effect to be obtained as with elements of infinite Q .

It will be seen from *fig. 12* that a third stub is fitted in the notch filter. This is connected to line PT (see *fig. 15*) and its sole purpose is to simplify adjustment. Finally lines PQ and ST have been made three-quarters of a wavelength long instead of a quarter wavelength for constructional reasons. The complete circuit is shown diagrammatically in *fig. 16*.

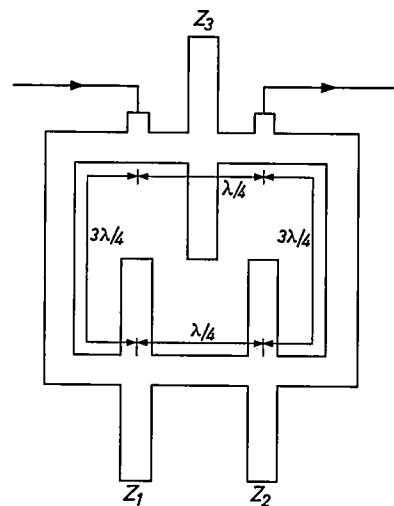

Fig. 16. The notch filter, built up from coaxial lines and coaxial stubs. The stub marked Z_3 is intended solely to facilitate adjustment.

The notch filter, as already mentioned, is followed by the detector, fitted with silicon diodes. The circuit is designed so as to satisfy the very high requirements laid down for linearity of the detection characteristic.

The phase correction filter of the monitoring re-

ceiver is composed of a number of bridged-T sections. The properties of this filter are best represented by the "group delay" characteristic, as this is most suitable for practical measurement. The filter is normally given the characteristic shown in *fig. 17* but if desired a filter with a different characteristic can be supplied.

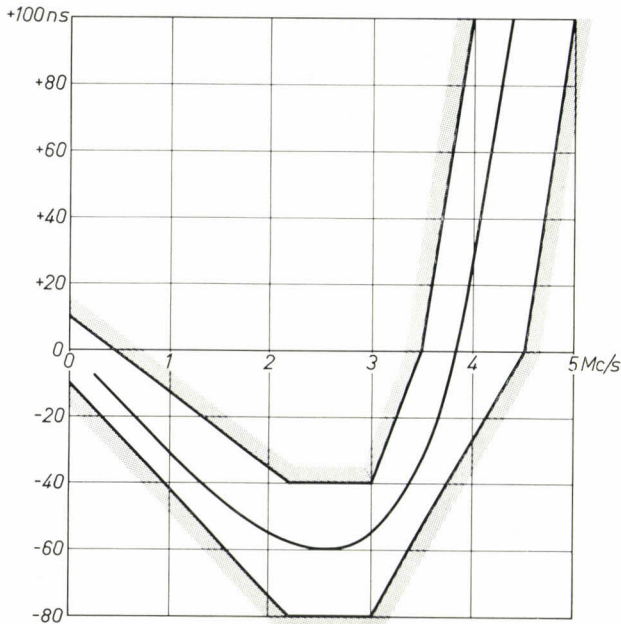

Fig. 17. Group delay characteristic for normal setting of the phase-correction filter in the Nyquist demodulator.

Paralleling transmitters

In the interest of continuity of television broadcasts, special measures are taken to avoid interruptions. For example, equipment can be duplicated. For economic reasons and to be certain that stand-by equipment will not fail at the very moment its services are needed, it is desirable to keep this equipment in operation. A good solution to the problem is, having decided upon the operating power of the transmitter, to have this power provided by two transmitter units, each of half the power and operating in parallel. If one of the units fails the transmission will go on without interruption, although at reduced power.

When two transmitters are connected in parallel in this way, it can be assumed that their frequencies are determined by a common crystal oscillator, and that their phase relationship is therefore permanently fixed. Two courses are then available. The first possibility is to feed both output signals to a bridge circuit for combination. The composite signal then goes from the bridge circuit to the aerial via the common aerial feeder. The drawback of this arrangement is that a

broadcast can still be interrupted by a fault in the bridge circuit, the feeder or the aerial. If it is desired to eliminate even that possibility, the aerial can be divided into two identical parts and the two transmitters connected to these half aerials by separate feeders. No bridge circuit is then needed and the signals combine after radiation from the aerials.

Although the second arrangement reduces the chance of interruptions during broadcasts to a minimum, it was found, when Philips Telecommunicatie Industrie set up a transmitter operating on this principle, that certain precautions have to be taken in building and tuning the two halves of the aerial if unwanted side effects are to be avoided.

These side effects are due to the fact that in addition to the main lobe, whose axis generally slopes slightly downwards towards the horizon, the radiation pattern also comprises a number of side lobes. The minima between the various lobes are due to the fact that the signals of the two aerial halves in the direction of these minima are practically cancelled out by interference. In the case of a clear-cut minimum, when cancellation is practically complete, the residual component of the signal will depend very closely on the phase relation between the two signals radiated by the two half-aerials. As this phase relation also depends on the momentary frequency determined by the modulation, the picture quality may be very unfavourably affected, and negative pictures may even occur, in areas situated in the direction of radiation pattern minima. It will be obvious from what has been said that this drawback can be overcome by designing and adjusting the aerial so that no very pronounced minima occur.

Summary. The article describes a number of problems confronting the designer of television transmitters for ultra-high frequencies (470-960 Mc/s). When allowance is made for propagation conditions at these frequencies and the gain that can be attained with the aid of the directional effect of the transmitting aerial, transmitter outputs of 10-40 kW are found to be necessary. These outputs and the frequencies used bring designers to the limit of what is possible with triodes and tetrodes. Two types of transmitter built by Philips for these bands therefore employ klystrons. A description of the 10 kW four-cavity klystron type YK 1001 is followed by a description of the output stage tuning procedure. The four resonant cavities can be tuned in such a way that the conventional sideband suppression filter is made largely superfluous. The penultimate stage of the vision-transmitter employs a tetrode in grounded-grid connection and uses coaxial techniques throughout. The cathode current for this stage is supplied by the modulator, which has a very low internal resistance. The receiver used to monitor the quality of the transmitted signal has to possess extremely constant characteristics and is therefore of special design. The filters incorporated in it are composed of coaxial elements made partly of Invar. Finally the article points out possible sources of degradation in picture quality when transmitters are connected in parallel.