



TUNABLE S-BAND
MAGNETRON

Service Type CV3611

The data should be read in conjunction with the Magnetron Preamble.

ABRIDGED DATA

Mechanically tuned pulse magnetron, frequency variant of type 5657

Frequency range	2700 to 2900	MHz
Typical peak output power	1.0	MW
Magnet	separate, see note 9 on page 5	
Output	coaxial line; internal diameter of outer conductor 1.527 inches, diameter of inner conductor 0.625 inch	
Coupler	see page 7	
Cooling	forced-air	



GENERAL

Electrical

Cathode	indirectly heated	
Heater voltage (see note 1)	16	V
Heater current	3.1	A
Heater starting current, peak value not to be exceeded	15	A max
Cathode heating time (minimum) (see note 2)	2	min

Mechanical

Overall dimensions	10.523 x 7.233 x 4.624 inches max 267.3 x 183.7 x 117.5mm max	
Net weight	5½ pounds (2.5kg) approx	
Mounting position	any	
Tuning (see note 3)	mechanical	
Tuner revolutions to cover frequency range	150	max

Cooling (see note 4)	forced-air
----------------------	------------

MAXIMUM AND MINIMUM RATINGS (Absolute values)

These ratings cannot necessarily be used simultaneously, and no individual rating should be exceeded.

	Min	Max	
Heater voltage (see note 1)	14.4	17.6	V
Heater starting current (peak)	—	15	A
Anode voltage (peak)	—	32	kV
Anode current (peak)	—	70	A
Input power (peak)	—	2.0	MW
Input power (mean) (see note 5)	—	1.2	kW
Duty cycle	—	0.001	
Pulse length	—	2.5	μ s
Rate of rise of voltage pulse (see note 7)	100	200	kV/ μ s
Anode temperature (see note 4)	—	100	$^{\circ}$ C
Cathode terminal temperature	—	100	$^{\circ}$ C
V.S.W.R. at the output coupler	—	1.5:1	
Ambient pressure for satisfactory operation	500	—	mm Hg
Pressurising (see note 8):			
input circuit	—	45	lb/in ²
output circuit	—	45	lb/in ²

TYPICAL OPERATION

Operational Conditions

Heater voltage	8.0	8.0	V
Magnetic field (see note 9)	2700	2700	gauss
Anode current (peak)	50	70	A
Pulse length	0.5	1.0	μ s
Pulse repetition rate	1500	500	p.p.s.

Typical Performance

Anode voltage (peak)	30	30	kV
Output power (peak)	700	1000	kW
Output power (mean)	525	500	W

TEST CONDITIONS AND LIMITS

The valve is tested to comply with the following electrical specification

Test Conditions

	Oscillation		
	1	2	
Magnetic field (see note 9)	2700	2700	gauss
Heater voltage (for test)	10	10	V
Anode current (mean)	35	35	mA
Duty cycle	0.0005	0.0006	
Pulse length (see note 6)	1.0	2.0	μ s
V.S.W.R. at the output coupler	1.15:1	1.15:1	
Rate of rise of voltage pulse (see note 7)	200	200	kV/ μ s

Limits

	Oscillation 1		Oscillation 2		
	Min	Max	Min	Max	
Anode voltage (peak) (see note 10)	27	32	—	—	kV
Output power (mean) (see note 10)	400	—	400	—	W
Frequency (see note 11)	2700	2900	—	—	MHz
R.F. bandwidth at ¼ power (see note 12)	—	2.5	—	—	MHz
Frequency pulling (v.s.w.r. not less than 1.5:1)	—	15	—	—	MHz
Stability (see notes 10 and 13)	—	0.5	—	—	%
Heater current					see note 14
Temperature coefficient of frequency					see note 15

LIFE TEST

The quality of all production is monitored by the random selection of valves which are then life-tested under Oscillation 1 conditions. If the valve is to be operated under conditions other than those specified herein, English Electric Valve Company Ltd. should be consulted to verify that the life of the valve will not be impaired.

End of Life Criteria (under Test Conditions Oscillation 1)

Output power (mean)	320	W min
R.F. bandwidth at ¼ power	2.5	MHz max
Stability (see note 13)	1	% max

NOTES

1. With no anode input power.

During high voltage operation it is essential to operate the heater according to the following schedule:

Mean Input Power (W)	Heater Voltage (V)
1000–1200	8.0
800–1000	10.5
600–800	13
400–600	15
less than 400	16

The above schedule is valid only for pulse repetition rates of 300p.p.s. or greater.

The valve heater shall be protected against arcing by the use of a minimum capacitance of 4000pF shunted across the heater directly at the input terminals; in some cases a capacitance as high as 2 μ F may be necessary depending on the equipment design. For further details see the preamble to this section.

2. It has been verified that the valve will operate at ambient temperatures as low as -55°C . At this temperature the minimum cathode heating time is 3 minutes.
3. Tuning is achieved by rotating a splined shaft which can be fitted to the valve in two positions as shown on the outline drawing. The splined shaft mates with S.S. White 2666X end fitting ($1\frac{3}{32}$ inch diameter).
4. The anode temperature must be kept below the limit specified by means of a suitable flow of air over the cooling fins.
5. The various parameters are related by the following formula:
$$P_i = i_{apk} \times v_{apk} \times D_u$$
where P_i = mean input power in watts
 i_{apk} = peak anode current in amperes
 v_{apk} = peak anode voltage in volts
and D_u = duty cycle.
6. Tolerance $\pm 10\%$.

7. The rate of rise of voltage is the slope of the steepest tangent to the leading edge of the voltage pulse above 80% amplitude. Any capacitance used in the viewing system must not exceed 6.0pF.
8. The mounting plate and the guard pipe are fitted to the valve in a manner to permit pressurising of the input and the output circuit of the valve. At the maximum pressure of 45 lb/in² absolute, the leakage will not exceed 0.5 litre (N.T.P.) per minute.
9. The valve is designed for use with a separate magnet which must conform with the specification given at the top of page 12. The axis of the magnetic field must be coincident with the axis of the anode, and the north pole of the magnet must be adjacent to the cathode terminal. A suitable magnet, type MA244, is available.
If an electro-magnet is used, the pole tip dimensions should be as shown on page 12.
10. These tests are carried out with the valve tuned to 2700, 2800 and 2900MHz.
11. The valve will tune over the indicated frequency range.
12. The specification limit for bandwidth applies over the whole tuning range.
13. With the valve operating into a v.s.w.r. of 1.5:1 phased to give maximum instability. Pulses are defined as missing when the r.f. energy level is less than 70% of the normal energy level in the rated frequency range of the valve. Missing pulses are expressed as a percentage of the number of input pulses applied during the last 3 minutes of a test interval not to exceed 6 minutes.
14. Measured with heater voltage of 16V and no anode input power, the heater current limits are 2.8A minimum, 3.4A maximum.
15. Design test only. The maximum frequency change with anode temperature change (after warming) is $-0.07\text{MHz}/^{\circ}\text{C}$.

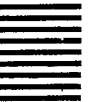

X-RAY WARNING

High voltage magnetrons emit a significant intensity of X-rays not only from the cathode sidearm but also from the output waveguide. These rays can constitute a health hazard unless adequate shielding for X-ray radiation is provided. This is a characteristic of all magnetrons and the X-rays emitted correspond to a voltage much higher than that of the anode.

TYPICAL PERFORMANCE CHART

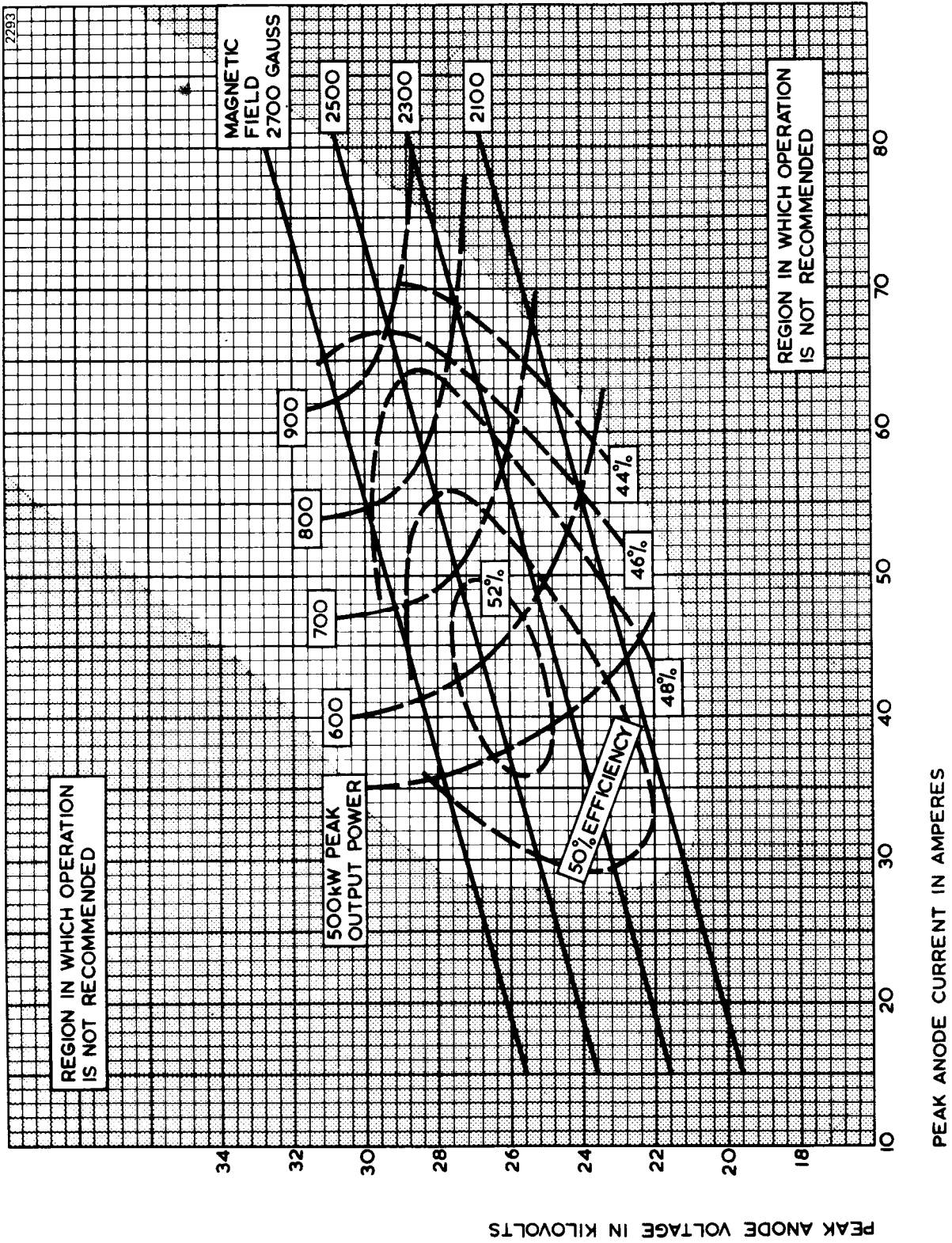

COUPLER (All dimensions without limits are nominal)

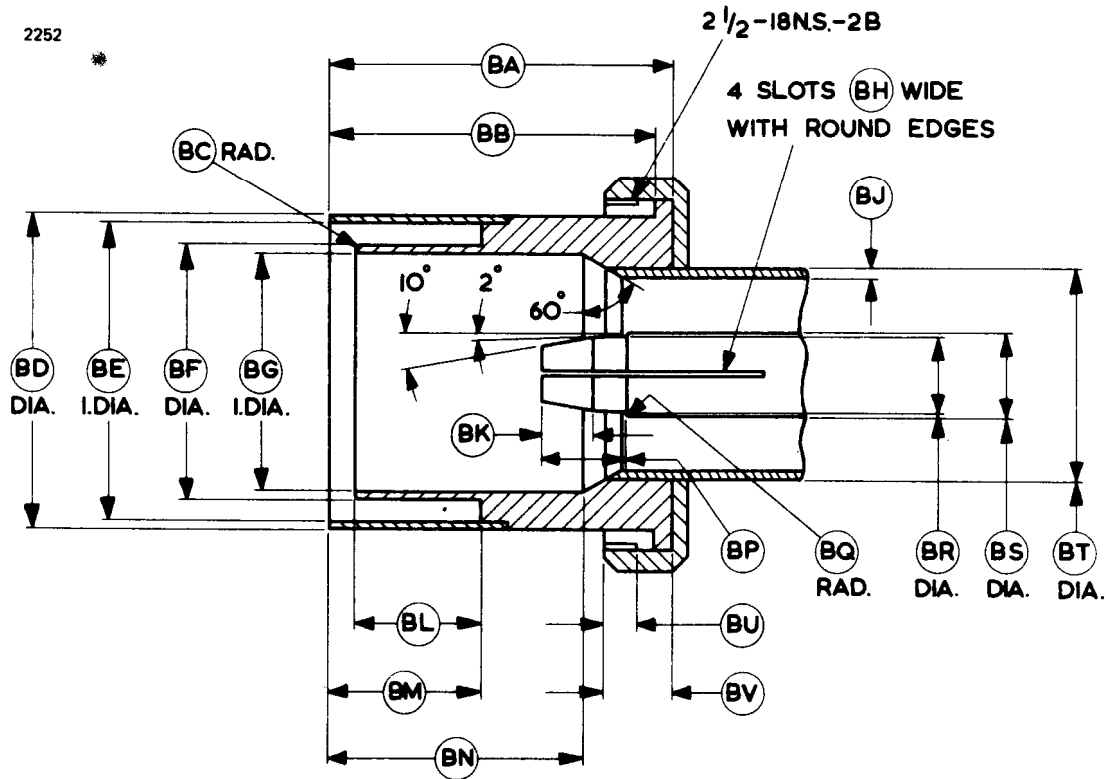

Ref	Inches	Millimetres	Ref	Inches	Millimetres
BA	2.531 ± 0.015	64.29 ± 0.38	BL	0.937 ± 0.003	23.800 ± 0.076
BB	2.402 ± 0.005	61.01 ± 0.13	BM	1.125 ± 0.003	28.575 ± 0.076
BC	0.031 ± 0.015	0.79 ± 0.38	BN	1.875 ± 0.005	47.63 ± 0.13
BD	2.310 ± 0.002	58.674 ± 0.051	BP	0.625 ± 0.015	15.88 ± 0.38
BE	2.185 ± 0.002	55.499 ± 0.051	BQ	0.016 ± 0.015	0.41 ± 0.38
BF	1.875 ± 0.002	47.625 ± 0.051	BR	0.576 ± 0.002	14.630 ± 0.051
BG	1.720 ± 0.002	43.688 ± 0.051	BS	0.625	15.88
BH	0.030	0.76	BT	1.625	41.28
BJ	0.049	1.24	BU	0.250 ± 0.015	6.35 ± 0.38
BK	0.375 ± 0.015	9.53 ± 0.38	BV	0.500 ± 0.015	12.70 ± 0.38

Millimetre dimensions have been derived from inches.

OUTLINE

2292

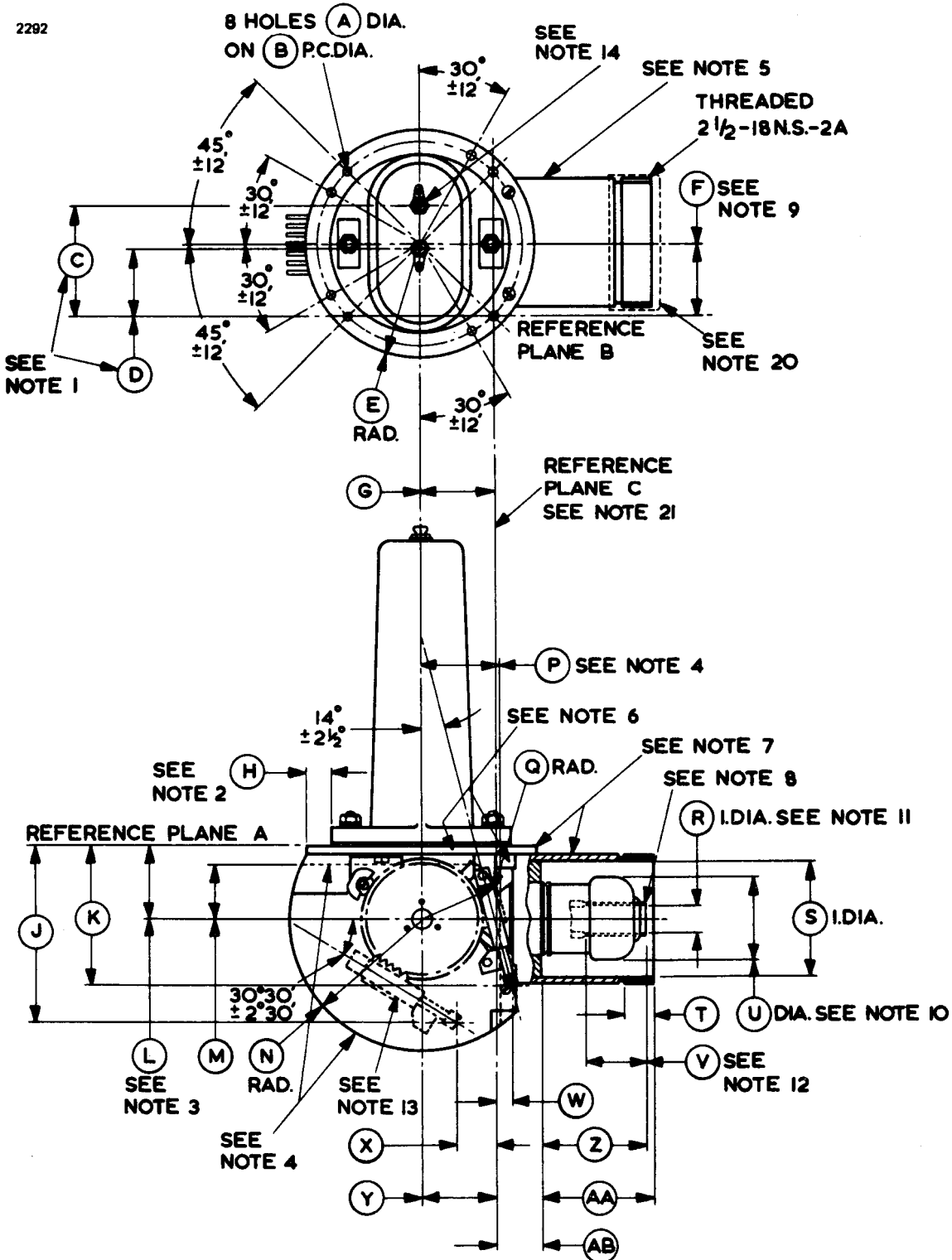

Outline Dimensions (All dimensions without limits are nominal)

Ref	Inches	Millimetres	Ref	Inches	Millimetres
A	0.210 ± 0.005	5.33 ± 0.13	T	0.593 min	15.06 min
B	4.064 ± 0.006	103.23 ± 0.15	U	1.620 max	41.15 max
C	2.156	54.76	V	1.125 min	28.58 min
D	1.359	34.52	W	0.313	7.95
E	2.281 ± 0.015	57.94 ± 0.38	X	0.756	19.20
F	1.437 ± 0.020	36.50 ± 0.51	Y	1.437	36.50
G	1.437	36.50	Z	2.085 ± 0.025	52.96 ± 0.64
H	0.500 min	12.70 min	AA	2.297 ± 0.010	58.34 ± 0.25
J	3.500	88.90	AB	0.818 ± 0.015	20.78 ± 0.38
K	2.812	71.42	AC	6.313 ± 0.094	160.4 ± 2.4
L	1.440	36.58	AD	0.187	4.75
M	1.063 min	27.00 min	AE	1.440 ± 0.020	36.58 ± 0.51
N	2.656 max	67.46 max	AF	0.025	0.64
P	1.500 min	38.10 min	AG	0.563 ± 0.125	14.30 ± 3.18
Q	1.500 min	38.10 min	AH	0.575 ± 0.050	14.61 ± 1.27
R	0.555 ± 0.005	14.10 ± 0.13	AJ	1.740 max	44.20 max
S	2.321 ± 0.007	58.95 ± 0.18			

Millimetre dimensions have been derived from inches.

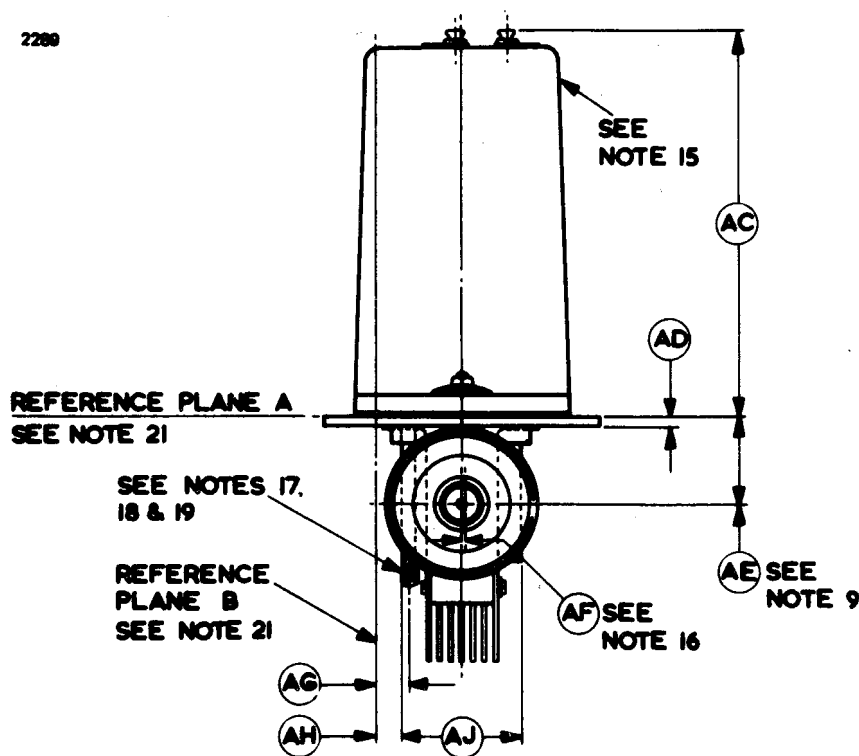

Outline Notes

1. The centres of the jack holes will be within a radius of 0.100 inch (2.54mm) of the location specified but spaced 0.797 ± 0.015 inch (20.24 ± 0.38 mm) with respect to each other.
2. With the valve resting on a plane surface, the flatness of this annular area will be such that a feeler gauge 0.015 inch (0.38mm) thick and 0.125 inch (3.18mm) wide will not enter more than 0.250 inch (6.35mm) at any point.
3. The periphery of the anode will lie within a 2.160 inches (54.86mm) diameter circle located as specified for the non-tunable side of the anode.
4. The maximum width specified by dimension 'AJ' applies to the area defined by the broken line and the circumference of the radiator.
5. The valve will be painted with black, heat resisting non-corrosive paint, except for the following paint free areas: top surface of mounting plate, parts above mounting plate, screw threads on guard pipe, all surfaces inside guard pipe, tuning gear, stop, and worm shaft assembly.
6. All joints on the mounting plate and guard pipe will be soldered to provide hermetic seals.
7. The valve may be supported by the mounting plate or guard pipe.
8. There will be no sharp edges on the outside diameter at the end of the inner conductor.
9. Applies to the location of the centre line of the guard pipe only.
10. The centre line of the maximum diameter will be concentric with the centre line of the guard pipe to within 0.040 inch (1.02mm).
11. Applies to the inner conductor insert only. The centre line of the inner conductor insert will be concentric with the centre line of the guard pipe to within 0.025 inch (0.64mm).
12. Applies to the straight portion of the inner conductor wall.
13. Optional location of tuning spline. The valve will be supplied with the spline located as specified by the customer.

14. Hexagon locking head banana pin jack, hole 0.169 ± 0.005 inch (4.29 ± 0.13 mm) diameter x 0.593 inch (15.06mm) long as per Mil-E-1, latest issue.
15. The common cathode connection is marked with letter C.
16. This dimension shows the relation between a plane passing through the lateral centre of the anode, and a plane passing through the centre of the guard pipe.
17. The tuning mechanism will provide the full range of tuning with a maximum of 5 complete revolutions of the large tuning gear.
18. The spline for adjusting the tuning mechanism is as follows: 12 teeth, 48 pitch, 0.250 inch (6.35mm) pitch diameter.
19. The clearance between the tuning spline and the guard pipe will be sufficient to allow the use of S.S. White No. 2666X end fitting ($1^3/32$ inch diameter).
20. Protective guard for shipping purposes.
21. Reference plane A is defined as a plane passing along the face of the mounting plate.
Reference plane B is defined as a plane perpendicular to plane A and passing through the centre of the holes shown.
Reference plane C is defined as a plane mutually perpendicular to planes A and B and passing through the centre of the hole as shown.



PERMANENT MAGNET SPECIFICATION

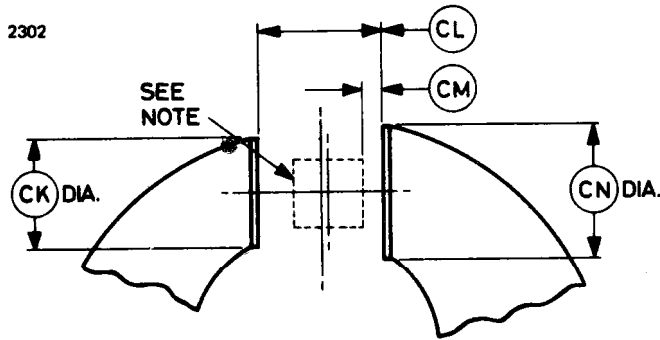

Ref	Inches	Millimetres	Ref	Inches	Millimetres
CK	1.625	41.28	CM	0.270	6.86
CL	1.800 ± 0.005	45.72 ± 0.13	CN	2.000	50.80

Millimetre dimensions have been derived from inches.

Note The variation of magnetic field within a cylinder 1.000 inch (25.4mm) long and 0.900 inch (22.86mm) diameter situated as shown and coaxially between the poles must not exceed ± 140 gauss.

ELECTRO-MAGNET POLE PIECES

Magnet with Single Conventional Pole Piece

Magnet with Distortion Pole Piece

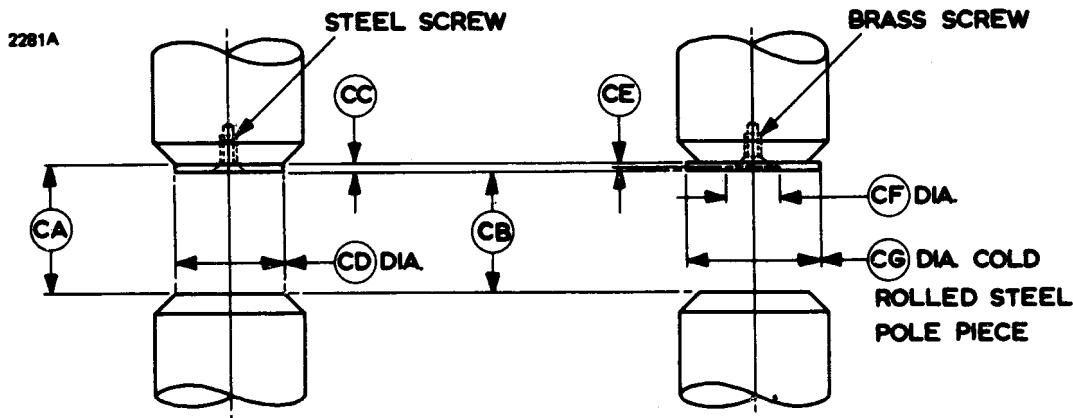

Ref	Inches	Millimetres	Ref	Inches	Millimetres
CA	1.925 ± 0.005	48.90 ± 0.13	CE	0.031 ± 0.015	0.79 ± 0.38
CB	1.800 ± 0.005	45.72 ± 0.13	CF	0.786 ± 0.005	19.96 ± 0.13
CC	0.125 ± 0.015	3.18 ± 0.38	CG	2.000 ± 0.015	50.80 ± 0.38
CD	1.625 ± 0.015	41.28 ± 0.38			

Millimetre dimensions have been derived from inches.