

The data should be read in conjunction with the Magnetron Preamble.

ABRIDGED DATA

Precision tuned pulse magnetron for linear accelerators. The tuning drive will mechanically tune the tube to within 50 kHz of any point in the frequency range and has been designed to be driven remotely by an electric motor.

Frequency range (see note 1)..... 2856 to 2859 MHz
 Peak output power (nominal) 5.0 MW
 Magnet and launching section separate electromagnet and launching section assembly MG6364
 Isolator (see note 2)..... use of an isolator is recommended
 Output..... no. 10 waveguide (72.14 x 34.04 mm internal)
 Cooling..... water and forced-air, or water and SF₆

GENERAL DATA

Electrical

Cathode indirectly heated
 Heater voltage (see note 3) 13 V
 Heater current 14 A
 Heater starting current, peak value, not to be exceeded..... 40 A max
 Cathode pre-heating time (minimum) 6.0 minute

Mechanical

Overall dimensions see outline
 Net weight..... 8 kg approx
 Mounting position..... any
 Tuning drive splined shaft, to mate with S.S. White EX977 remote control flexible shaft
 Tuner turns between stops 346 turns

Accessories

Electromagnet/launching section MG6364
 Sidearm radiation absorber..... MG6372
 1 µF coaxial capacitor (see note 3)..... MA997A

Cooling

The magnetron anode and the electromagnet have integral water jackets.

The magnetron requires a water flow of 18 to 27 litres/minute; the pressure drop across the water jacket is 103 kPa maximum.

The electromagnet requires a water flow of 4.5 litre/minute at a pressure drop of 14 kPa.



The magnetron output window may be cooled by either high pressure air or an arc suppressant gas such as SF₆. When the output window is cooled by high pressure air, a flow of not less than 0.085 m³/minute (NTP) into the air inlet at the base of the launching section is required. If SF₆ is used, then no gas flow is required to cool the window. See note 7.

Low pressure air cooling may be required for the cathode terminal.

Whilst e2v technologies has taken care to ensure the accuracy of the information contained herein it accepts no responsibility for the consequences of any use thereof and also reserves the right to change the specification of goods without notice. e2v technologies accepts no liability beyond the set out in its standard conditions of sale in respect of infringement of third party patents arising from the use of tubes or other devices in accordance with information contained herein.

e2v technologies (uk) limited, Waterhouse Lane, Chelmsford, Essex CM1 2QU United Kingdom Holding Company: e2v technologies plc

Telephone: +44 (0)1245 493493 Facsimile: +44 (0)1245 492492

Contact e2v by e-mail: enquiries@e2v.com or visit www.e2v.com for global sales and operations centres.

© e2v technologies (uk) limited 2013

A1A-776915 Version 1, June 2013

Template: DF764388A-7

114814

END OF LIFE CRITERIA

(Under the above Test Conditions, see note 17)

Output power (mean) (see note 20).....	2180	W min
RF bandwidth at 6 dB	2.0	MHz max
Frequency (see note 14).....	2856 to 2859	MHz
Stability	1.0	% max

NOTES

1. The frequency range 2856 to 2859 MHz is achieved under all conditions. The total available tuning range is 10 MHz. The frequency at any tuner setting will increase by 630 kHz per kW reduction in mean input power. For other conditions, contact e2v technologies.
2. The magnetron must be protected from the load by an isolator or circulator. The maximum VSWR at 2856 MHz is 1.3:1 and must not exceed 2:1 over the range 2800 to 3500 MHz.
3. With no anode input power.

Prior to the application of anode voltage, the cathode must be heated to the required initial temperature by the application of 13 V to the heater for at least six minutes. Within 30 seconds after the application of anode voltage the heater must be reduced as follows:

Mean input power (kW)	Heater voltage (V)
0 - 2	12.0
2 - 4	10.0
4 - 6	8.0
6 - 7	6.0

The heater voltage must be maintained within ±5% of the specified value. A rectified supply is recommended for operating the magnetron. The use of any AC supply may cause frequency modulation. e2v technologies should be consulted if the magnetron is to be operated with any supply other than DC.

A coaxial lead must be used to connect the magnetron to the filament transformer or pulse transformer, the outer being the cathode pulse connection. Capacitors must be used to prevent pulse voltages being applied to the heater, either from unbalance of a bifilar pulse transformer or by induction from the pulse current; this protection must be effective both for normal operation and in the event of the magnetron sparking. Capacitors up to 10 µF may be required, shunted by small high frequency capacitors.

4. The minimum air pressure in the output waveguide can vary with the peak power level at which the magnetron is operated. It should not be less than 172 kPa at 1 MW, 241 kPa at 3 MW and 310 kPa at 5 MW. At the maximum pressure of 448 kPa the leakage will not exceed 0.03 litre (NTP) per minute.

The output waveguide may also be filled with an arc suppressant gas, such as SF₆ to a minimum static gauge pressure of 28 kPa. When using such a gas, it is mandatory that the waveguide be emptied and refilled with new arc suppressant gas at regular intervals to avoid possible dilution or contamination. The interval should not exceed 2 months or 100 hours of high voltage application, whichever is reached first. The gas should also be replaced immediately if arcing in the output waveguide is suspected, as such arcing may cause loss of stability in the magnetron.

5. Measured at the point indicated on the electromagnet outline drawing; the axial distribution must be that produced by the MG6364 electromagnet or authorised equivalent.
6. The modulator must have an efficient overswing damping system, such that the pulse energy delivered to the magnetron following an arcing pulse does not appreciably exceed the normal pulse energy. An interlock relay must be used to trip the modulator in the event of excessive magnetron arcing, preferably operated by the overswing diode current. The trip should operate if the magnetron arcs for 25 consecutive pulses. Positive overswing at the end of the voltage pulse should be less than 10% of drive voltage.

7. The various parameters are related by the formula:

$$P_i = i_{apk} \times V_{apk} \times D_u$$

where P_i = mean input power in watts
 i_{apk} = peak anode current in amperes
 V_{apk} = peak anode voltage in volts
and D_u = duty cycle

8. The rate of rise of voltage is defined as the steepest tangent to the leading edge of the voltage pulse above 80% amplitude.
9. Tolerance ±10%.
10. The load termination of the magnetron during this test is a waveguide with a VSWR of less than 1.1:1 at the oscillation frequency and less than 1.5:1 between 3200 and 3500 MHz.
11. The magnetron tuning range includes the two limits given.
12. Using test conditions with a duty cycle of 0.00008 (1 kW mean input power), the lowest frequency obtained will not be greater than 2855 MHz).
13. Measured with a VSWR of 1.3:1 at the frequency of oscillation, varied through all phases.
14. Pulses are defined as missing when the RF energy level is less than 70% of the normal energy level in the frequency range 2852 to 2861 MHz. Missing pulses are expressed as a percentage of the number of input pulses applied during any 5 minute interval of a 10 minute test period.
15. Measured with a heater voltage of 13 V and no anode input power, the heater current limits are 13 A minimum, 15 A maximum.
16. Design test only. The maximum frequency change with anode temperature change (after warming) is -0.05 MHz/°C.
17. The heater will be operated at 8.0 V for the duration of the life test and for subsequent specification tests.
18. If the mean output power falls below 2500 W, the duty cycle may be reduced to 0.0005; end of life is reached when the magnetron is unable to deliver 5.0 MW peak power with a maximum mean current of 133 mA.

TYPICAL PERFORMANCE CHART

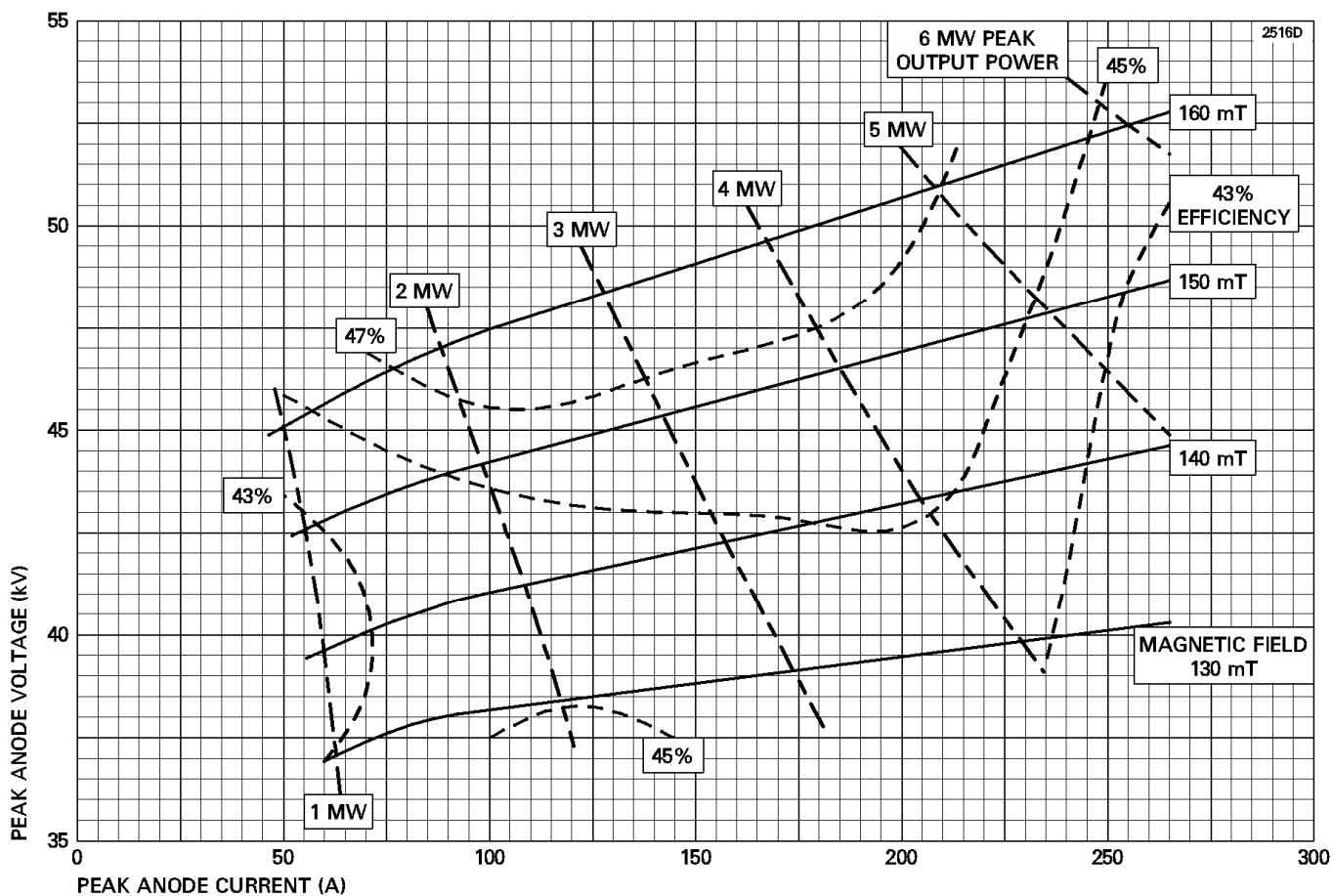

OUTLINE

(All dimensions without limits are nominal)

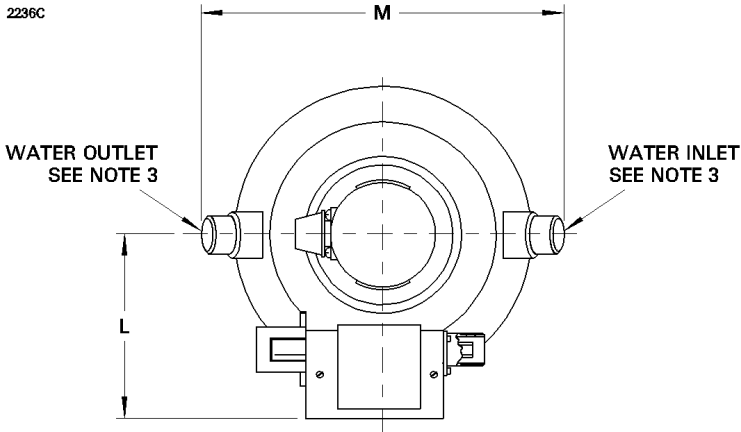

Ref	Millimetres
A	254.0 max
B	222.3 max
C	146.7 max
D	33.02 ± 3.18
E	57.15 max
F	120.7
G	76.2 max
H	116.2
J	144.5
K	101.6 max
L	94.0 max
M	190.5

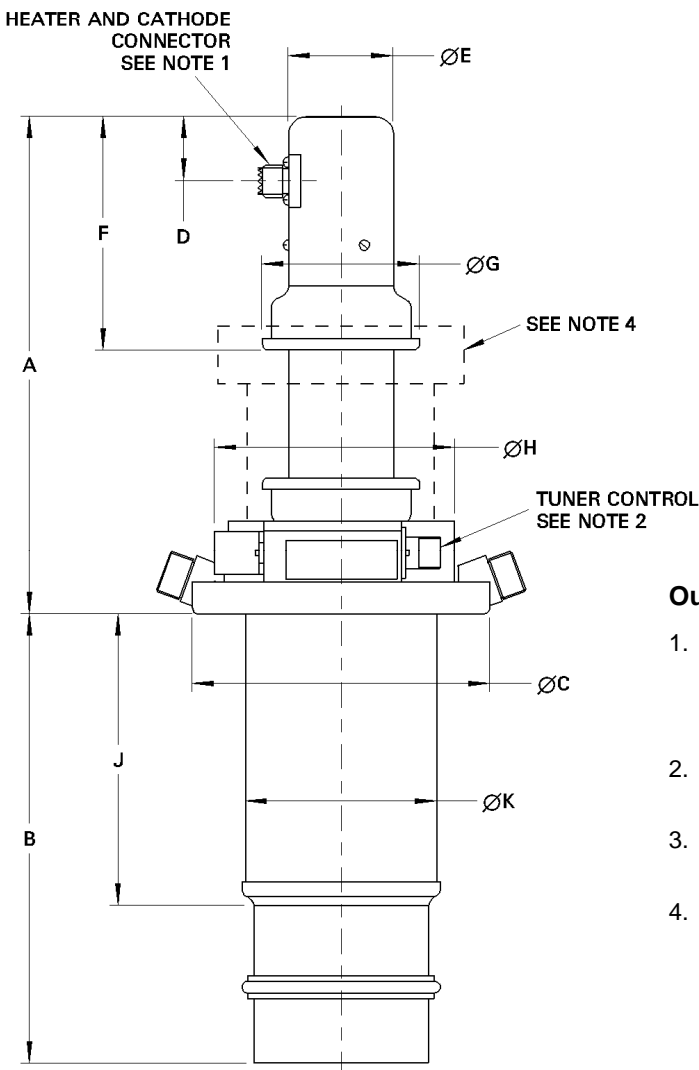

Outline Notes

1. Heater-cathode connector is a UHF 50 Ω coaxial socket; the corresponding plug is MIL STD PL259 with PTFE insulator. The cathode connection is the outer shell of the socket.
2. Splined shaft, to mate with S.S. White EX977 remote control flexible shaft.
3. Water connections 1/2-inch BS screwed pipe to BS 2051 part 2.
4. Radiation absorber MA761 optional accessory.

HEALTH AND SAFETY HAZARDS

e2v technologies magnetrons are safe to handle and operate, provided that the relevant precautions stated herein are observed. e2v technologies does not accept responsibility for damage or injury resulting from the use of electronic devices it produces. Equipment manufacturers and users must ensure that adequate precautions are taken. Appropriate warning labels and notices must be provided on equipments incorporating e2v technologies devices and in operating manuals.



High Voltage

Equipment must be designed so that personnel cannot come into contact with high voltage circuits. All high voltage circuits and terminals must be enclosed and fail-safe interlock switches must be fitted to disconnect the primary power supply and discharge all high voltage capacitors and other stored charges before allowing access. Interlock switches must not be bypassed to allow operation with access doors open.



RF Radiation

Personnel must not be exposed to excessive RF radiation. All RF connectors must be correctly fitted before operation so that no leakage of RF energy can occur and the RF output must be coupled efficiently to the load. It is particularly dangerous to look into open waveguide or coaxial feeders while the device is energised. Screening of the cathode sidearm of high power magnetrons may be necessary.



X-Ray Radiation

High voltage magnetrons emit a significant intensity of X-rays not only from the cathode sidearm but also from the output waveguide. These rays can constitute a health hazard unless adequate shielding for X-ray radiation is provided. This is a characteristic of all magnetrons and the X-rays emitted correspond to a voltage much higher than that of the anode.



Toxic Material

This device contains fluorinated elastomers (Viton O-rings). If exposed to temperatures above 400 °C these degrade and form hydrofluoric acid. This is a serious health hazard if skin contact occurs. Access to these components is not possible unless the device is damaged or dismantled.