



**DIONICS, INC.**

65 Rushmore Street  
Westbury, NY 11590

Phone: (516) 997-7474

Fax: (516) 997-7479

Website: www.dionics-usa.com

## **GAS DISCHARGE DISPLAY SEGMENT DRIVERS**

### **DI-232**

### **DI-242**

#### General Description:

The DIONICS DI-232 and DI-242 circuits are designed to drive gas discharge display devices from signals originating from MOS or TTL circuitry. Each output is a switched programmable constant current sink with a voltage compliance of 80 Volts or 125 Volts.

These circuits provide for simple interface with display such as Beckman, SP-452, Cherry W410-1051 or Dale PD-16A040.

#### Features:

- ✓ High Breakdown Voltage: 80V or 125V.
- ✓ High Input Voltage Capability: 40V
- ✓ TTL or MOS Compatible
- ✓ Each Output Programmed by a Single Resistor
- ✓ Requires Few Additional Components
- ✓ Dielectrically Isolated Integrated Circuits
- ✓ DC Restoring Input Diode

#### Package Layout:

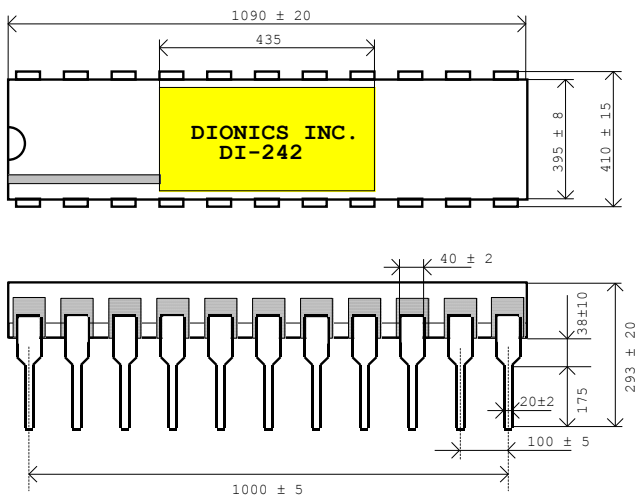

#### **Pin Connections**

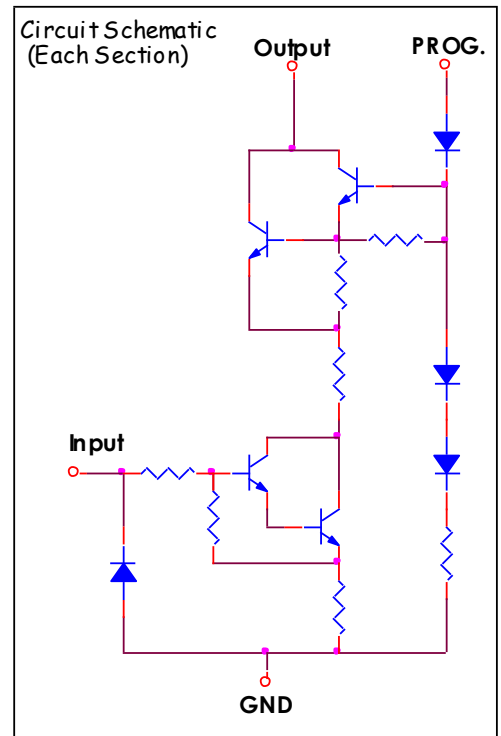
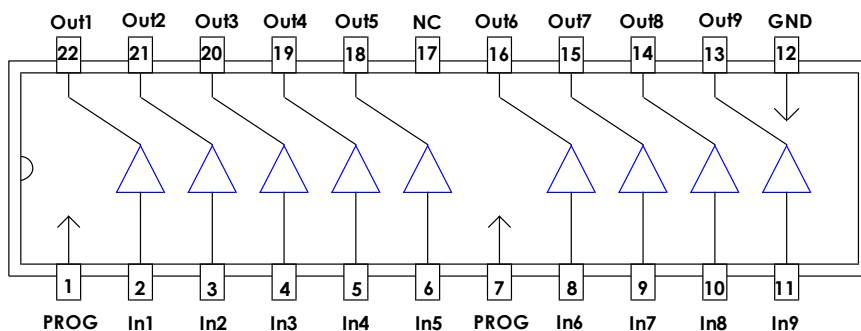

### Absolute Maximum Rating ( $T_a = 25^\circ\text{C}$ )

Characteristic	Symbol	Notes	Limits	Units
Input Voltage	$V_{in}$	Measured With Respect to GND Terminal	40	V
Output Current	$I_o$		5	mA
Output Voltage DI-232	$V_o$	Measured With Respect to GND Terminal	80	V
Output Voltage DI-242	$V_o$	Measured With Respect to GND Terminal	125	V
Power Dissipation DI-232; DI-242	$P_D$	Derate at 8 mW/ $^\circ\text{C}$ Above $25^\circ\text{C}$ Ambient	1100	mW
Storage Temperature	$T_s$		-55 to +125	$^\circ\text{C}$
Operating Temperature	$T_o$		0 to +70	$^\circ\text{C}$

### Electrical Characteristics ( $T_a = 25^\circ\text{C}$ )

Parameter	Symbol	Conditions	Min.	Typ.	Max.	Units
Output Saturation Voltage	$V_o$ (SAT)	$I_o=1\text{mA}$ ; $V_i=3.5\text{V}$ ; $R_p=27\text{k}\Omega$ ; $V_p=10\text{V}$		5		V
Output Leakage Current	$I_o$ (OFF)	$V_o$ = Rated Voltage; $V_i = 0.4\text{V}$ ; $R_p = 27\text{k}\Omega$ ; $V_p = 10\text{V}$		0.1	10	$\mu\text{A}$
Output Current Match	$\Delta I_o / I_o$	$V_o=60\text{V}$ ; $V_i=3.5\text{V}$ ; $R_p=27\text{k}\Omega$ ; $V_p=10\text{V}$		$\pm 5$	$\pm 10$	%
Output Current	$I_o$ (ON)	$V_o=60\text{V}$ ; $V_i=3.5\text{V}$ ; $R_p=27\text{k}\Omega$ ; $V_p=10\text{V}$	1.1	1.2	1.5	mA
Input Current	$I_i$	$V_i = 7.0\text{V}$	250	370	500	$\mu\text{A}$

### Typical Application:

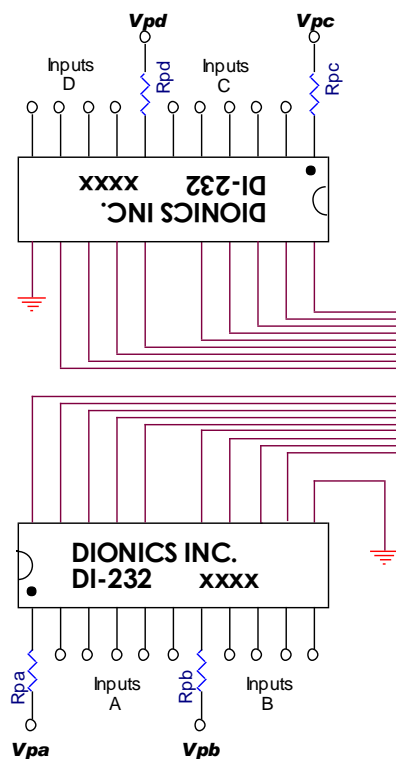

$V_p$ : PROGRAM VOLTAGE  
 $R_p$ : PROGRAM RESISTOR

### ALPHA NUMERIC DISPLAY

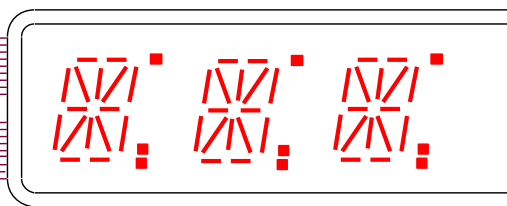

TWO DI-232 PROVIDE 4 GROUPS OF OUTPUTS EACH HAVING DIFFERENT AND INDEPENDENT PROGRAMMED SEGMENT CURRENT LEVELS

