

ELECTRON TUBE DATA SHEET
WESTERN ELECTRIC 450 A ELECTRON TUBE

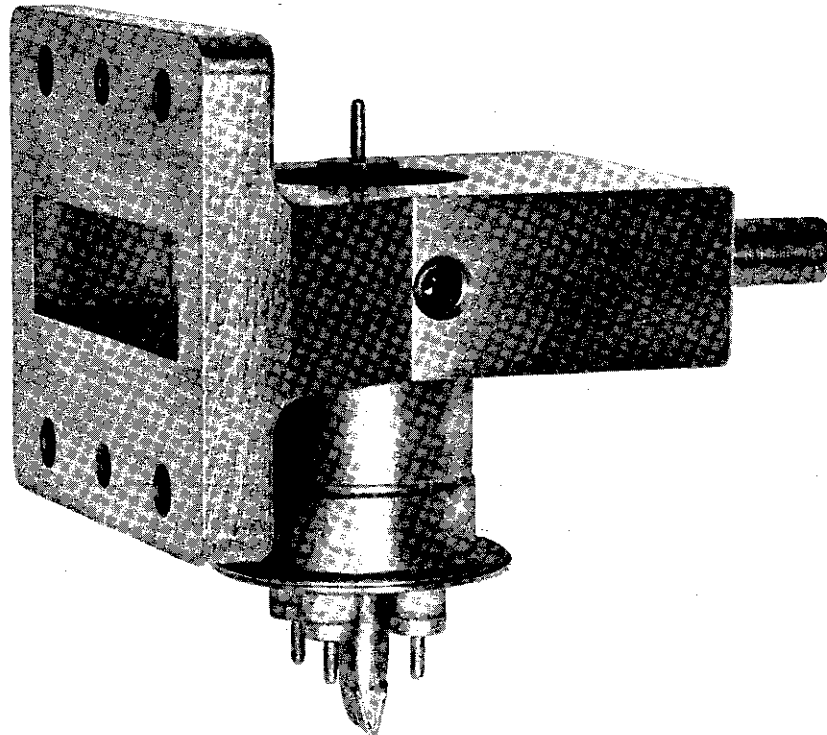

DESCRIPTION

The 450A is a reflex oscillator designed to operate as a frequency deviator in the TH Microwave Relay System. It is designed to operate from 6.090 gigacycles to 6.175 gigacycles. The tube has a waveguide output.

CHARACTERISTICS

Heater Voltage	6.3 V
Resonator Voltage	450 Vdc
Reflector Voltage @ 6.175 Gc	-118 Vdc
Power Output	150 mW

MAXIMUM RATINGS, Absolute System

	Symbol	Min.	Max.	Units
Heater Voltage	E_h	5.8	6.8	V
Resonator Voltage	E_{rs}	-	525	Vdc
Reflector Voltage	E_r	-50	-400	Vdc
Cathode Current	I_k	-	65	mAdc
Heater-Cathode Voltage	E_{hk}	-	±50	v
Body Temperature	T_E	-	110	C
Reflector Circuit Resistance	R_r	-	10^6	ohm

MECHANICAL DATA

Cathode	Unipotential
Mounting Position	Any
Output	1.59" x 0.795" Waveguide
Dimensions and Pin Connections	See Outline Drawing

ELECTRICAL CHARACTERISTICSOperating Conditions (See Notes 1 & 2)

	Symbol	Nominal	Units
Heater Voltage	E_h	6.3	V
Resonator Voltage	E_{rs}	450	Vdc
Reflector Voltage (See Note 3 & Fig.1)	E_r	-75 to -150	Vdc

Operating Characteristics

	Symbol	Min.	Typ.	Max.	Units
Heater Current	I_h	0.82	0.88	0.94	A
Cathode Current	I_k	-	48	56	mAdc
Power Output (6.09 to 6.175 Gc, See Note 4)	P_o	50	Fig. 2	250	mW
Electronic Tuning Range @ 6.175 Gc	ΔF	35	56	75	Mc
Resonator Modulation Sensitivity @ 6.175 Gc	$\Delta F/\Delta E_{rs}$	-	0.24	0.50	Mc/V
Reflector Modulation Sensitivity @ 6.175 Gc	$\Delta F/\Delta E_r$	1.0	1.4	1.8	Mc/V
Mechanical Tuning Range		6.09	-	6.175	Gc

TYPICAL REFLECTOR VOLTAGE VS FREQUENCY

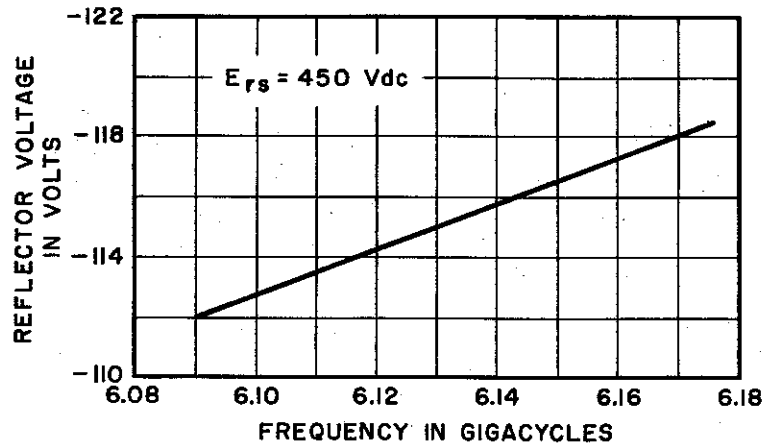

FIGURE 1

TYPICAL POWER OUTPUT VS FREQUENCY

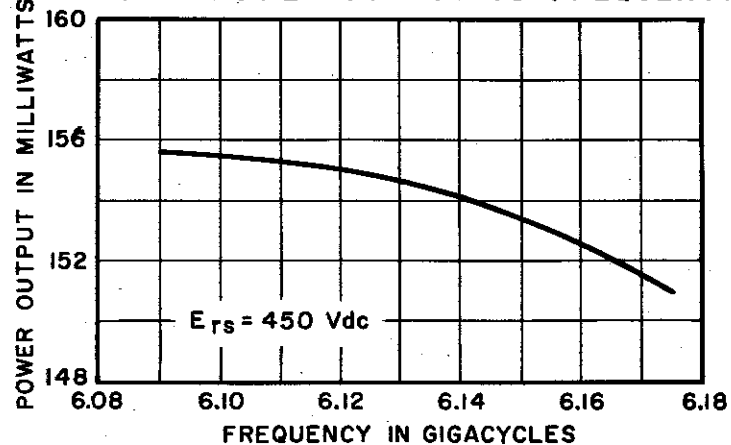

FIGURE 2

Note 1: Operation at or near maximum values will result in decreased life. Operation near typical values is recommended.

Note 2: The following turn-on procedure is recommended:

- a. Apply heater voltage and wait ten minutes.
- b. Apply reflector voltage.
- c. Apply resonator voltage.

Note 3: Reflector voltage is that voltage, measured from cathode to reflector, which produces maximum power at the frequency to which the tube is mechanically tuned.

Note 4: The tube is to be operated into a load having a VSWR less than 1.05:1.

Caution-Resonator voltage must never be applied unless there is at least -50 volts on the reflector.

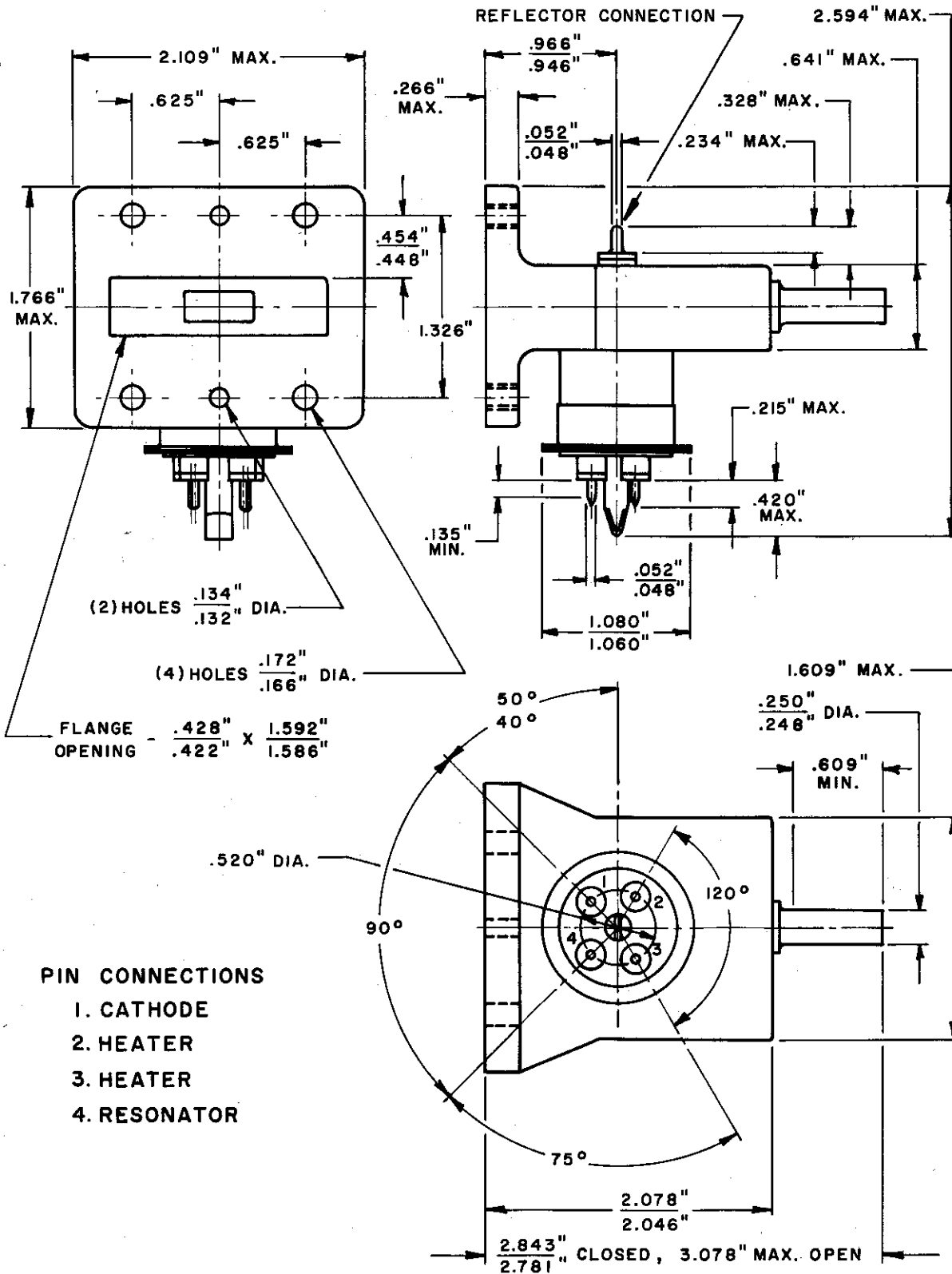

A development of Bell Telephone Laboratories, the research laboratories of the American Telephone and Telegraph Company and the Western Electric Company.