

ELECTRONIC VALVE SPECIFICATIONS

SPECIFICATION AD/CV5326 ISSUE No.1 DATED 22nd AUGUST 1960

AMENDMENT No. 1

Page 4 Outline Drawing

Amend the heater pin diameter of $3/8" \pm 0.005"$ to read $3/16" \pm 0.005"$

January 1965.

NJ/253640

T.V.C. for A.S.W.E.

VALVE ELECTRONICADMIRALTY SURFACE WEAPONS ESTABLISHMENT

CV5326

Specification AD/CV5326	<u>SECURITY</u>	
Issue 1 dated 22nd August, 1960.	<u>Specification</u>	<u>Valve</u>
To be read in conjunction with K1001 and B.S.448	Unclassified	Unclassified

<u>TYPE OF VALVE:</u> Disc seal common grid triode		<u>MARKING</u> See K1001/4
<u>CATHODE:</u> Indirectly heated		
<u>ENVELOPE:</u> Metal, glass		
<u>PROTOTYPE:</u> CV2163/E2908		
<u>RATING (Note A)</u> (All limiting values are absolute)		<u>Note</u> Dimensions and connections (See Note D) See Drawing on Page 4
Heater voltage (V)	16.0	
Heater current (A)	7.3	
Max. pulse anode voltage (kV)	13.0	
Max. anode dissipation (W)	1500	
Max. mean anode current during pulse (A)	50	
Amplification factor	45	
Mutual conductance (mA/V)	50	
Max. pulse duration (μ secs)	10	
<u>CAPACITANCES (pF)</u>		<u>MOUNTING POSITION</u>
C _{ag}	28	Vertical, base down
C _{gc}	30	
C _{ac}	0.5	
<u>NOTES</u>		
A. The above ratings are for pulse operation only.		
B. For this dissipation forced air cooling shall be provided by not less than 150 cubic feet of air per minute through the anode cooler with a pressure drop of the order of 3" of water and approximately 20 cubic feet per minute of air through the grid cooler. The temperature on the outside of the anode flange, on the inner edge of the grid disc and on the base of the Cathode Connector shall not exceed 100°C. These conditions apply to ambient temperatures up to 30°C. Air must be flowing before the power is switched on, and it is recommended that the flow be continued for approximately 2 minutes after power is switched off.		
C. Measured at V _a = 1.5 kV I _a = 0.8A.		
D. Rigid connection must be made to anode and grid only.		
E. This voltage must not be exceeded under any condition.		

The following clauses of K1001 will apply:- 1 to 5 inclusive (except 5A to 5F inclusive), 8, 9, 10, 13, 14, 15 and Appendices II, III and V.

As part of the manufacturing process, before valves are submitted to the tests below, they shall be operated in an approved high voltage pulse circuit to ensure operation in Service equipments.

Test Conditions - unless otherwise specified								
		V_h (V)	V_a (V)	V_g (V)	I_a (A)			
		16	1,500	0	0.8			
K1001 Ref.	Test	Test Conditions	AQL %	Insp. Level	Sym- bol	Limits		Units
						Min.	Max.	
	<u>Group A omitted</u>							
	<u>Group B</u>							
	Heater current	$V_a = 0V$ $I_a = 0A$		100%	I_{g1}	6.6	8.0	A
	Mutual conductance	V_g - adjust peak grid swing $\pm 1V$. (Note 1).		100%	gm	35	-	mA/V
	Peak emission	Anode and grid strapped. Peak applied voltage = 1000V. $T_p = 2 \mu$ secs. pulse shaped sinusoidal p.r.f. 50 c/s. (Note 2).		100%	I_a	130	-	A
	<u>Group C</u>							
	Reverse grid current	V_g - adjust $I_a = 1.0A$ (Note 1)		100%	I_{g1}	-	100	μA
	Grid voltage (1)	V_g - adjust (Note 1)		100%	$-V_g$	5.0	20.0	V
	Grid cut-off Voltage	V_g - adjust (Note 1) $I_a = 0.025A$		100%	$-V_g$	-	70.0	V
	Change in grid voltage from value found in (1) above	$V_a = 1,700V$ V_g - adjust		100%	$-V_g$	3.7	5.5	V
	<u>Group D</u>							
	Capacitances	Measured on a 1 Mc/s bridge.		6 per month	C_{ag} C_{gc} C_{ac}	23.4 25.4 -	31.7 34.4 1.0	pF pF pF
	<u>Group E omitted</u>							
AV1/5	<u>Group F</u>							
	Life	Notes 2, 3.		1 in 20		500	-	hours

NOTES

1. For these tests forced air-cooling not greater than the minimum required in Note B on Page 1, shall be used.
2. This test to be conducted in an approved circuit, details of which may be obtained from the Specification Authorities.
3. Valves shall be tested in pairs in the transmitter. End of life shall be considered to be reached when a pair of valves fails to deliver 400 kW peak into the load. Two valves out of the first ten produced to any contract are to be life tested either until end of life or for 500 hours whichever is the less, and the hours run are to be recorded. If the valves are still satisfactory after 500 hours, two valves from the next twenty produced are to be life tested in a similar manner. Should these prove satisfactory, life testing is to continue at the inspection level specified. If any valves fail to meet the minimum specified life, sampling is to revert to that obtaining at the start of the contract, except that in any given test, a single catastrophic failure in less than 100 hours of one of the valves of a pair may be ignored, that valve being replaced and the test re-commenced without reversion to the higher inspection level. All life test samples required in excess of the inspection level quoted are to be provided by the manufacturer at his expense.

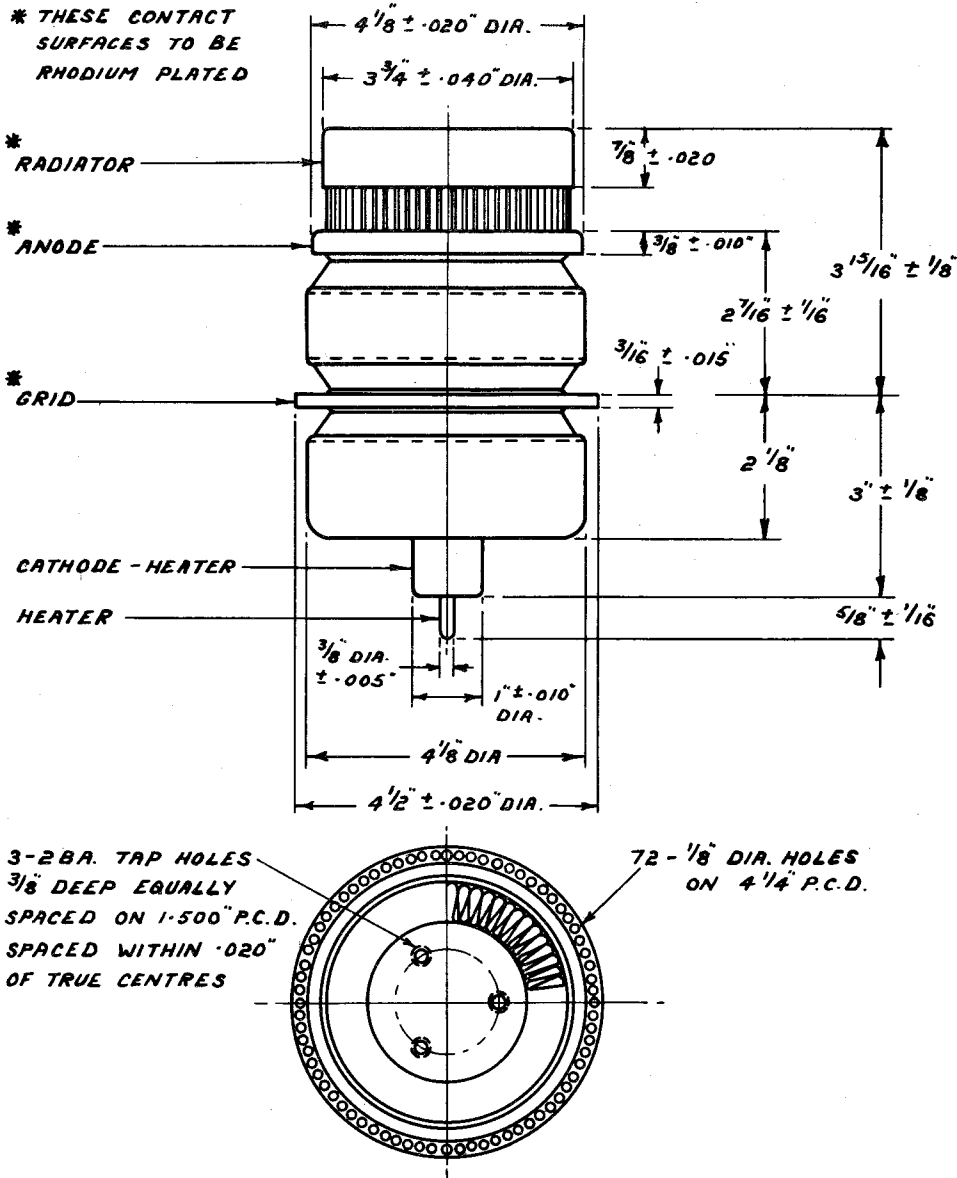

NOTES

1. ALL EXTERNAL CONTACT SURFACES TO BE RHODIUM PLATED.
2. RIGID CONNECTION TO BE MADE TO ANODE OR GRID ONLY.
3. MAXIMUM ECCENTRICITY FOR ALIGNMENT OF ANODE, GRID, CATHODE & HEATER CONTACTS TO BE 1/32.